

Water Supply System Modeling Report

Hetch Hetchy / Local Simulation Model

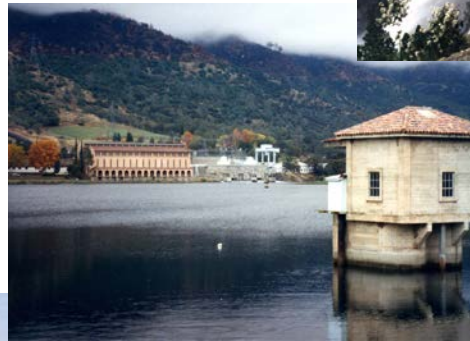

San Francisco Public Utilities Commission
Prepared by Daniel B. Steiner, Consulting Engineer
May 2007

Table of Contents

1. Introduction	1
2. System Description	3
2.1 Hetch Hetchy and the San Joaquin System	3
2.2 Bay Area System	7
2.3 Regional Water System Customers	8
2.4 System Operations	11
2.4.1 Normal System Operations	11
2.4.2 Operations during Drought Periods	13
3. Overview of Model	15
3.1 Water Demands	16
3.2 Water Availability and System Performance Studies	16
3.2.1 System Firm Yield Study	16
3.2.2 Protocol for Modeling System Drought Response and Shortage Levels	18
3.3 Model Outputs	18
3.4 Generalized Model Representation	18
4. Model Inputs	23
4.1 Hydrology	23
4.1.1 Precipitation	23
4.1.2 Unimpaired Runoff and Reservoir Inflows	23
4.1.2.1 Unimpaired Runoff at La Grange Dam	23
4.1.2.2 Inflow to Hetch Hetchy Reservoir	23
4.1.2.3 Inflow to Lake Lloyd and Lake Eleanor	27
4.1.2.4 Unregulated Flow Below Hetch Hetchy Reservoirs	27
4.1.2.5 Inflow to Calaveras Reservoir	27
4.1.2.6 Runoff at Alameda Creek Diversion Dam	27
4.1.2.7 Unregulated Runoff below Alameda Creek Diversion Dam	27
4.1.2.8 Inflow to San Antonio Reservoir	27
4.1.2.9 Inflow to Crystal Springs Reservoir	35
4.1.2.10 Inflow to San Andreas Reservoir	35
4.1.2.11 Inflow to Pilarcitos Reservoir	35
4.1.2.12 Unregulated Runoff below Pilarcitos Reservoir	35
4.1.3 Evaporation	40
4.2 Facilities	40
4.2.1 Reservoirs	40
4.2.1.1 Tuolumne River Reservoirs	41
4.2.1.2 Bay Area Reservoirs	42
4.2.2 Pipelines and Conveyance Facilities	43
4.2.3 Power Facilities	44
4.2.4 Treatment Facilities	44
4.3 Operations	45
4.3.1 Tuolumne System Operations	45
4.3.1.1 Hetch Hetchy Reservoir	45
4.3.1.2 Lake Lloyd and Lake Eleanor	45
4.3.1.3 Water Bank Account	46
4.3.1.4 San Joaquin Pipelines	46
4.3.1.5 Lower Cherry Aqueduct	47
4.3.1.6 Hetch Hetchy Power Operations	47
4.3.1.7 Don Pedro Project	48
4.3.2 Bay Area System Operations	50
4.3.2.1 Water Demands and Deliveries	50
4.3.2.2 Pilarcitos Reservoir and Coastside CWD	50
4.3.2.3 San Andreas Reservoir and Crystal Springs Reservoir	50
4.3.2.4 San Antonio Reservoir and Calaveras Reservoir	51

4.4 Minimum Stream Release Requirements	51
4.4.1 Hetch Hetchy Reservoir	51
4.4.2 Lake Lloyd and Lake Eleanor	52
4.4.3 Don Pedro Reservoir	53
4.4.4 Calaveras Reservoir	54
4.4.5 San Antonio Reservoir	55
4.4.6 Peninsula Reservoirs	55
5. Modifications to HH/LSM for WSIP Analyses	57
5.1 Retail Customer Recycled Water/Groundwater/Conservation	57
5.2 Wholesale Customer Recycled Water/Groundwater/Conservation	57
5.3 Westside Basin Conjunctive Use Program	57
5.4 Tuolumne River Water Transfer	57
5.5 Regional Dry-year Desalination	57
5.6 Oceanside Desalination	57
5.7 Lower Tuolumne River Diversion	57
5.8 Delta Diversion	58
6. Model Verification	59
6.1 Parsons/CH2MHill Review	59
6.1.1 Conclusions	59
6.1.2 Recommendations	60
6.2 Comparison of Model Results with Current Operations	60
7. References and Sources of Additional Information	61

1. Introduction

The City and County of San Francisco (San Francisco), through the San Francisco Public Utilities Commission (SFPUC), owns and operates a complex water supply system that serves 2.4 million people, primarily in San Francisco and the south San Francisco Bay region. The system extends about 167 miles, from Yosemite National Park to San Francisco, and develops water supply from three principal watersheds: the Tuolumne, Alameda, and Peninsula watersheds. The amount of water available to the SFPUC Regional Water System varies depending on meteorological conditions and several authorized, legislated and assigned obligations. The SFPUC operates the Regional Water System to meet customer water demand as fully and efficiently as it can in light of the fact that the amount of water available to it varies from year-to-year.

The operations of the Regional Water System are complex, involving numerous reservoirs, pipelines, and pumping plants. The SFPUC utilizes a computerized mathematical model to assist in the evaluation of its operations: the Hetch Hetchy/Local Simulation Model water supply planning model (referred to as HH/LSM or model). The purpose of this document is to describe this model in terms of the Regional Water System, and how the model represents the system.

HH/LSM incorporates information about key aspects of the SFPUC Regional Water System including facilities (i.e., reservoir and conveyance capacities) and operating procedures and “rules” that determine how and when water is moved through the system to SFPUC customers. Operations of Regional Water System can be generally described by rules and strategies affecting the operation of the Bay Area system and rules and strategies affecting the operation of the Hetch Hetchy Water and Power System (Hetch Hetchy). Although generally viewed separately, the two sub-systems are integrally linked, and are interdependent to each other.

The Bay Area system is depicted as a linked series of inflows, reservoirs, conveyance routes and areas of water demand. Numerous operational constraints are incorporated including considerations for downstream channel conveyance capacity, treatment plant capacity, and water transmission capacity. In general, the Bay Area system is operated to conserve local Bay Area watershed runoff and Tuolumne River water resources. Seasonal storage level objectives for each reservoir have been developed to guide an operation that will conserve local watershed runoff while recognizing an objective to provide emergency and drought protection storage. The operation provides empty reservoir storage space prior to the winter season. This reservoir space is filled with Bay Area watershed runoff and Tuolumne River water by late spring in order to carry maximum reservoir storage into the summer season.

The SFPUC Bay Area system is supplemented with diversions from the Tuolumne River Basin. The model integrates operations at the SFPUC’s three major reservoirs, Hetch Hetchy Reservoir, Lake Lloyd and Lake Eleanor with the operation of the Don Pedro Water Bank Account and the need for supplemental water from the Bay Area system. The operation of these reservoirs and the Don Pedro Water Bank Account is guided by two primary objectives: 1) conserve reservoir storage to optimize diversions, and 2) fulfill the entitlements of Modesto Irrigation District and Turlock Irrigation District (collectively referred to as “MID/TID” or the “Districts”) to flow of the Tuolumne River. Underlying the operations at SFPUC reservoirs are the minimum fishery release requirements prescribed for Hetch Hetchy Reservoir, Lake Lloyd and Lake Eleanor. Water that is released from SFPUC reservoirs and not diverted to San Francisco, and runoff that originates below SFPUC reservoirs flows to Don Pedro Reservoir. HH/LSM simulates the Districts’ operation of Don Pedro Reservoir, including simulation of canal diversions, flood control operations, and releases to meet flow requirements below La Grange Dam. The model also simulates the accounting for the Don Pedro Water Bank Account.

The model uses a watershed runoff forecasting routine (for snowmelt and rainfall) that projects the amount of runoff that can be expected to occur in the Tuolumne River Basin. Once the amount of anticipated runoff is projected, the runoff is compared to the availability of reservoir storage to capture the runoff and the anticipated releases required from the SFPUC reservoirs for downstream requirements and diversions to San Francisco. If SFPUC reservoirs are projected to spill, discretionary releases are managed in order to enhance power generation from Hetch Hetchy.

The model provides a simulation of Regional Water System operations for a long-duration period depicting historical hydrologic conditions. The 82-year period includes many different types and sequences of actual hydrological events that have occurred ranging from flood events to droughts of different magnitude and duration. The long-term 82-year historical record is used in the model to represent the range of hydrologic conditions that could occur in the future. The model is used to assess how the system would perform in terms of an assumed system configuration and assumed operational objectives.

2. System Description

The Regional Water System currently provides an annual average normal-year delivery of 265 million gallons per day (mgd), of which the Bay Area watershed resources provide on average approximately 15 percent of the water delivered by San Francisco. The local watershed facilities are operated to conserve local runoff for delivery and provide emergency and drought protection reservoir storage. The water demands that are not met with the conserved local runoff, about 85 percent of current deliveries, require the importation of water from the Tuolumne River Basin. The amount of water available to San Francisco from Hetch Hetchy is constrained by hydrology, physical facilities, and the institutional parameters that allocate the water supply of the Tuolumne River.

The Regional Water System is generally geographically delineated between Hetch Hetchy Water and Power Project facilities and Bay Area system facilities. Hetch Hetchy is generally comprised of the reservoirs, hydroelectric generation and transmission facilities, and water transmission lines from Hetch Hetchy Valley west to the Alameda East Portal. The local Bay Area water system is generally comprised of the facilities from this point west and includes the local watershed reservoirs and distribution system that delivers water to San Francisco's retail and wholesale customers. Figure 2-1 shows the major facilities of the San Francisco water system.

2.1 Hetch Hetchy and the San Joaquin System

Hetch Hetchy is operated to conserve water from the Tuolumne River watershed for consumptive municipal and industrial use and the production of hydroelectricity. The project is also operated to provide stream flows to benefit fisheries and other wildlife, and for recreation.

Hetch Hetchy Reservoir is located on the main stem of the Tuolumne River at Hetch Hetchy Valley and is formed by the water impounded by O'Shaughnessy Dam. Hetch Hetchy Reservoir has a capacity of 360,400 acre-feet (with drum gates raised, and 340,000 acre-feet with the drum gates lowered) with its inflow primarily occurring from snowmelt within a 459 square mile watershed that is located entirely within Yosemite National Park. The water from Hetch Hetchy Reservoir is used for municipal and industrial water supply, to fulfill downstream obligations and to generate hydroelectric power. Water from Hetch Hetchy Reservoir is delivered to customers without filtration since the quality of this water supply has warranted a filtration exemption from the U.S. Environmental Protection Agency (USEPA) and the California Department of Health Services (DHS). Under normal hydrologic operating conditions, Hetch Hetchy Reservoir is the only reservoir of the project that directly supplies water to the Bay Area.

San Francisco's other two impounding reservoirs in the Tuolumne River Basin, Lake Eleanor and Lake Lloyd (also called Cherry Reservoir) are used primarily to satisfy downstream obligations to Districts, produce hydroelectric power, and provide flows for fish and other wildlife, and recreational use. Although Lake Eleanor and Lake Lloyd do not normally supply water directly to the Bay Area, they facilitate San Francisco's use of Hetch Hetchy Reservoir for that purpose. Release of water from these reservoirs can partially fulfill San Francisco's downstream release obligations thereby allowing flows to be captured in Hetch Hetchy Reservoir for diversion to the Bay Area.

Lake Eleanor has a capacity of 27,100 acre-feet (with flashboards installed, 21,500 acre-feet without flashboards), and is located approximately three miles above the confluence of Eleanor and Cherry Creeks. Lake Lloyd is located on Cherry Creek about four miles above the confluence with Eleanor Creek. Lake Lloyd has a capacity of 273,300 acre-feet with flashboards installed, and 268,800 acre-feet without flashboards. Lake Eleanor and Lake Lloyd are linked by a tunnel and pump facilities that allow water to flow from Lake Eleanor to Lake Lloyd. As a result of this linkage, the two reservoirs may be operated as a single unit. If necessary during emergency or drought conditions, San Francisco can divert water from Cherry Creek through the Lower Cherry Aqueduct to Early Intake where the water can be diverted into the Mountain Tunnel for transport to the Bay Area. This diversion is not currently utilized for

Figure 2-1
Major Facilities of the SFPUC Regional Water System

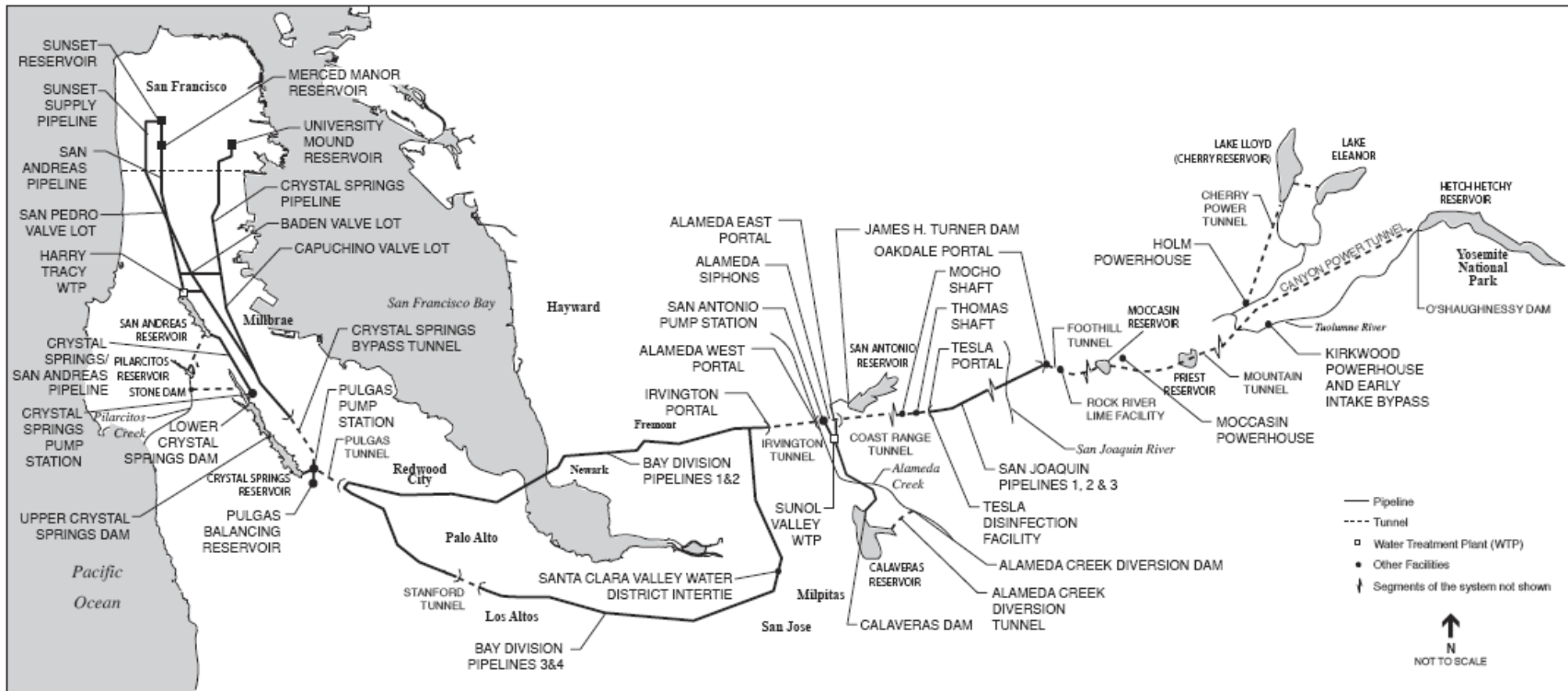

water supply delivery. In the event that water from Cherry Creek is diverted into Mountain Tunnel, filtration would be necessary per requirements of the USEPA and the DHS.

As a condition to federal authorization of the Hetch Hetchy, numerous conditions and obligations were imposed on San Francisco which included the requirement to recognize the prior rights of the Districts to divert water from the Tuolumne River. This obligation was formalized in 1913 in the Raker Act as flow entitlements to the Districts. Subsequently during the development of the Don Pedro Project, San Francisco and the Districts entered into agreements to specify the rights and entitlements of each party, and their respective responsibilities for the Don Pedro Project. Among other items, one of the agreements allocates storage space in Don Pedro Reservoir which creates for San Francisco a “water bank account.” San Francisco does not directly divert water from Don Pedro Reservoir; however, the water bank account allows San Francisco to balance the Districts’ water entitlements with the operation of Hetch Hetchy.

San Francisco’s maximum allocation of storage space in Don Pedro Reservoir varies from 570,000 acre-feet (during the flood control season) to 740,000 acre-feet. San Francisco’s water bank account grows when the Districts receive inflows to Don Pedro Reservoir greater than their entitlements, and conversely San Francisco debits the water bank account by diverting or storing water that would otherwise be within the entitlements of the Districts.

Water that is not released from Lake Eleanor and Lake Lloyd immediately below the impoundments is diverted for generation of hydroelectric power at Holm Powerhouse. Holm Powerhouse is located on Cherry Creek about two miles upstream of its confluence with the Tuolumne River and includes two turbine generators. Water released to Holm Powerhouse returns to Cherry Creek where it flows into the Tuolumne River and subsequently into Don Pedro Reservoir.

Water is diverted at O’Shaughnessy Dam for delivery to the Bay Area and for hydroelectric generation. Water that is diverted at O’Shaughnessy Dam flows through the Canyon Tunnel to the Kirkwood Powerhouse. The powerhouse has three turbine generators. From Kirkwood Powerhouse, water is directly diverted into the Early Intake Bypass, which carries the water into Mountain Tunnel. At times, water diverted to Kirkwood Powerhouse can exceed the conveyance capacity of Mountain Tunnel. At those times, flow that exceeds that capacity is released to the Tuolumne River and flows past Early Intake Dam. These releases eventually reach Don Pedro Reservoir.

Groveland Community Services District, a retail customer, receives its delivery from Mountain Tunnel. Diversions to Mountain Tunnel flow into Priest Reservoir which is located on Rattlesnake Creek near the town of Big Oak Flat. From there the water flows to Moccasin Powerhouse and through two turbine generators. Local watershed inflow at Priest Reservoir is bypassed with the Grizzly Creek diversion structure. Flows through the powerhouse enter Moccasin Reservoir where the water either flows through the Moccasin Reservoir Bypass into the Foothill Tunnel, or is released into Moccasin Creek where it flows to Don Pedro Reservoir. Some of the Moccasin Creek release is diverted through a low head generator. Local watershed runoff to Moccasin Reservoir is bypassed with the Moccasin Creek Diversion Dam and conduit. The Foothill Tunnel runs sixteen miles from Moccasin Reservoir and connects with the three San Joaquin Pipe Lines at the Oakdale Portal.

The San Joaquin Pipelines convey water across the San Joaquin Valley to the Tesla Portal. From Tesla Portal, water travels through the Coast Range Tunnel and emerges at the Alameda East Portal. Figure 2.1-1 shows a general schematic of the linkage of facilities in the Tuolumne River Basin and the facilities traversing the San Joaquin Valley and Coast Range, west to Alameda East Portal.

**Figure 2.1-1
Tuolumne River Basin Facilities, West to Alameda East Portal**

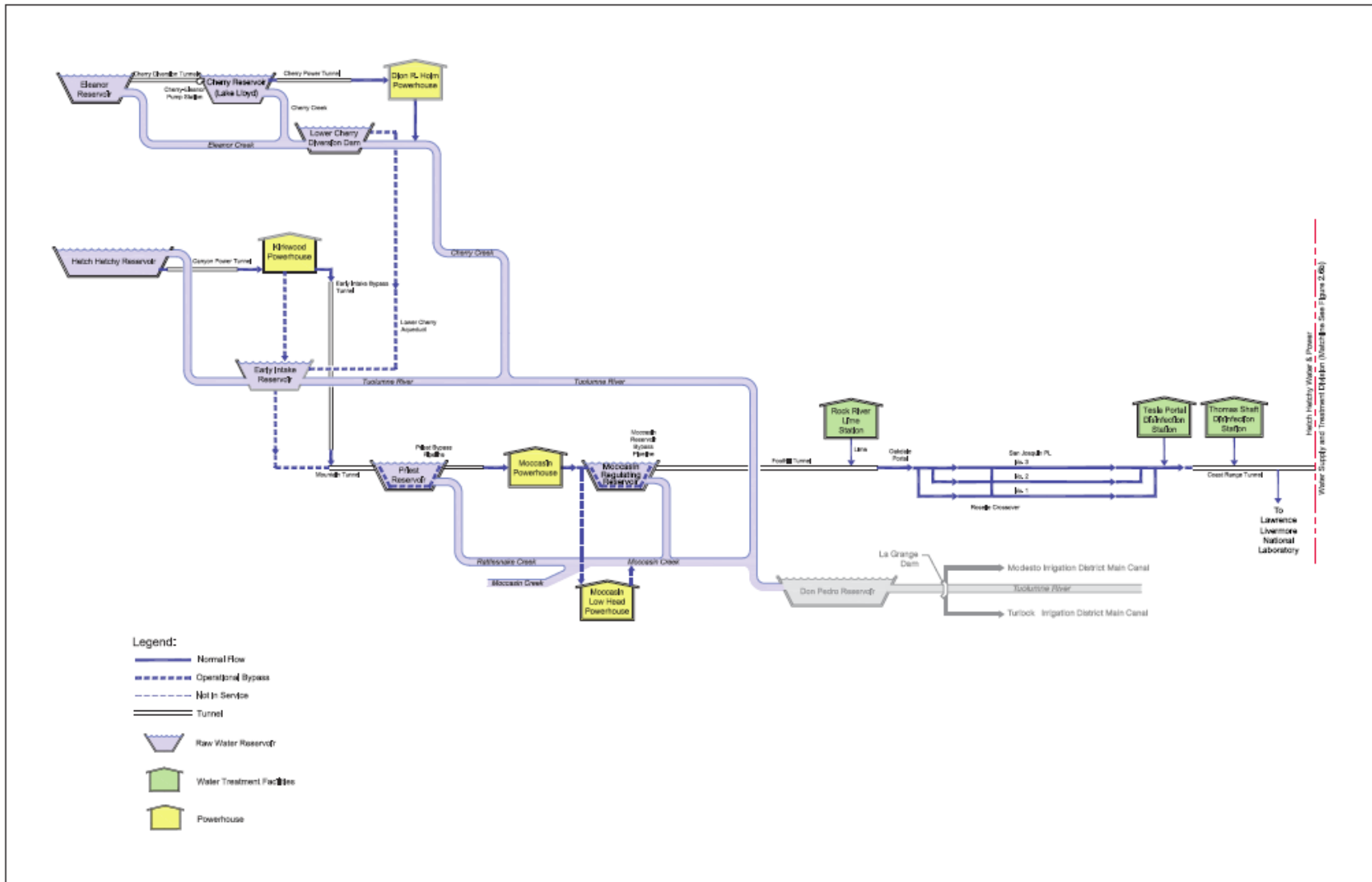

2.2 Bay Area System

Water supplies from the Alameda watershed are combined with the Hetch Hetchy water supply in Sunol Valley. The Alameda watershed generally refers to the SFPUC-owned lands that are located within the much larger hydrologic boundaries of the greater southern Alameda Creek watershed. Local water supply sources contributing to the water system include Alameda, Arroyo Hondo, and Calaveras Creeks, which provide inflow to Calaveras Reservoir, and San Antonio Creek, which flows to San Antonio Reservoir.

The Alameda East Portal is the connection between the Coast Range Tunnel and the Alameda Siphons. The Alameda Siphons are three pipelines that cross Sunol Valley and travel beneath Alameda Creek, connecting the Coast Range Tunnel at the Alameda East Portal to the Irvington Tunnel at the Alameda West Portal. At the Alameda Siphons, Hetch Hetchy water is combined with water from the Calaveras and San Antonio Reservoirs that has been treated at the Sunol Valley Water Treatment Plant (Sunol Valley WTP). Water deliveries to the Town of Sunol, a retail customer, occur from two of the siphons downstream of the mixing point of Sunol Valley WTP treated water with Hetch Hetchy water.

Calaveras Reservoir, located at the south end of the Alameda watershed, collects and stores water from the local watershed, including drainage from Calaveras Creek and Arroyo Hondo. The reservoir was constructed to a capacity of 96,800 acre-feet (31.5 billion gallons, "bg") but is currently constrained by California Safety of Dams (DSOD) interim operating restrictions to an operating capacity of 37,800 acre-feet (12.4 bg). Alameda Diversion Dam and Tunnel divert flows from the southern Alameda Creek watershed into Calaveras Reservoir. Water from Calaveras Reservoir flows by gravity through the Calaveras Pipeline to the Sunol Valley WTP for treatment, and then flows to the Alameda Siphons where it is combined with the Hetch Hetchy water supply. Water from Calaveras Reservoir can also be transferred to San Antonio Reservoir.

San Antonio Reservoir and Turner Dam impound water from San Antonio Creek. This reservoir can also receive and store water from the Hetch Hetchy water supply or from Calaveras Reservoir. The reservoir was constructed to a capacity of 50,600 acre-feet (16.4 bg). Water stored in San Antonio Reservoir must be conveyed in the San Antonio Pipeline to the Sunol Valley WTP for treatment before it can be added to the system at the Alameda Siphons.

At the Alameda West Portal, the combined flows enter the Irvington Tunnel. The Irvington Portal in Fremont, at the west end of Irvington Tunnel is where the tunnel connects to the four Bay Division Pipelines (BDPL). BDPL Nos. 1, 2, 3, and 4, two sets of two parallel pipelines, serve multiple purposes: providing water to customers in the East Bay, South Bay, and Peninsula through turnouts along the pipelines; conveying water to users in the northern Peninsula and in San Francisco; and transmitting water to Crystal Springs and San Andreas Reservoirs to supplement local storage in the Bay Area.

BDPL Nos. 1 and 2 pass through the cities of Fremont and Newark, cross San Francisco Bay at the Dumbarton Strait, and continue through East Palo Alto, Redwood City, Menlo Park, and Atherton. The SFPUC's Palo Alto Pipeline is fed by BDPL Nos. 1 and 2.

BDPL Nos. 3 and 4 extend around the south end of San Francisco Bay. The two pipelines pass through the cities of Fremont, Milpitas, San Jose, Santa Clara, Sunnyvale, Mountain View, Los Altos, Palo Alto, Menlo Park, Atherton, Woodside, and Redwood City. BDPL Nos. 3 and 4 converge into a tunnel at Stanford. BDPL Nos. 3 and 4 reconnect with BDPL Nos. 1 and 2 at the Pulgas Portal entrance to Pulgas Tunnel just west of Redwood City.

Water that is not directly delivered to SFPUC customers flows from Pulgas Portal into Crystal Springs Reservoir. There, Hetch Hetchy water is stored along with water from the local watersheds for later use. As needed, water from Crystal Springs Reservoir is pumped into San Andreas Reservoir.

Crystal Springs Reservoir, which is comprised of upper and lower reservoirs, was constructed to a capacity of approximately 69,360 acre-feet (22.6 bg). Since 1983, the DSOD has placed operational restrictions on Lower Crystal Springs Dam which limits the operational storage to approximately 58,300

acre-feet (19.0 bg). San Andreas Reservoir is supplied water from Crystal Springs Reservoir, Pilarcitos Reservoir and its own watershed. It has a capacity of 19,000 acre-feet (6.2 bg). Before entering the SFPUC distribution system, all water from the peninsula reservoirs is treated at the Harry Tracy Water Treatment Plant.

Pilarcitos Reservoir is located on Pilarcitos Creek on the west slope of the Coast Range in San Mateo County. Pilarcitos Dam collects local drainage and water from Pilarcitos Creek, forming Pilarcitos Reservoir. The reservoir has a capacity of 2,980 acre-feet (0.97 bg). Stone Dam, two miles downstream of Pilarcitos Dam, captures drainage along Pilarcitos Creek below the dam. Water from Pilarcitos Reservoir may be diverted to San Andreas and Crystal Springs Reservoirs through a system of tunnels and pipes. Almost half of Pilarcitos Reservoir supply is used to serve the Half Moon Bay area through wholesale service to the Coastside County Water District (Coastside CWD). Figure 2.2-1 shows a general schematic representation of Bay Area system facilities.

2.3 Regional Water System Customers

The SFPUC provides water delivery service to retail and wholesale customers in San Francisco, San Mateo, Santa Clara, Alameda, and Tuolumne Counties to a total of about 2.4 million people. The SFPUC serves about one-third of its water supplies directly to retail customers located primarily in San Francisco, and about two-thirds of its water supplies to 27 wholesale customers by contractual agreement. The 27 wholesale customers consist of 25 cities and water districts and 2 private utilities in San Mateo, Santa Clara, and Alameda Counties, which are represented by the Bay Area Water Supply and Conservation Agency (BAWSCA). Some of these customers have other sources of water in addition to what they receive from the SFPUC system. The SFPUC also provides service to some isolated regional retail customers along the water system, including customers in Tuolumne County. Table 2.3-1 lists the major Regional Water System customers and indicates the wholesale customers that receive water supplies from sources other than the SFPUC. Figure 2.3-1 provides a map of the service area in the Bay Area. The SFPUC currently provides an average annual normal-year delivery of about 265 mgd.

**Table 2.3-1
SFPUC Regional Water System Customers**

Wholesale Regional Customers (BAWSCA Members)		Major Regional Retail Customers
Peninsula	South Bay	
California Water Service Company (South San Francisco* and Mid-Peninsula)	Alameda County Water District*	City and County of San Francisco San Francisco County Jail (San Bruno) San Francisco International Airport (San Mateo Co.) Lawrence Livermore National Laboratory (Site 200/300) National Aeronautics and Space Administration (Santa Clara Co.) Town of Sunol (Alameda Co.) Groveland Community Services District (Tuolumne Co.)
City of Brisbane	Mid-Peninsula Water District	
Guadalupe Valley Municipal Improvement District	California Water Service Company (Bear Gulch*)	
City of Burlingame	City of Hayward	
City of Daly City*	City of Menlo Park*	
City of Millbrae	City of Milpitas*	
City of San Bruno*	City of Mountain View*	
Coastside County Water District*	City of Palo Alto*	
Estero Municipal Improvement District (Foster City)	City Redwood City*	
North Coast County Water District	City of San Jose (North San Jose Service Area*)	
Town of Hillsborough	City of Sunnyvale*	
Westborough County Water District	City of Santa Clara*	
	City of East Palo Alto	
	Purissima Hills Water District	
	Skyline County Water District	
	Stanford University*	

* Indicates wholesale customers that receive water supplies from sources other than the SFPUC.

**Figure 2.2-1
Bay Area System Facilities**

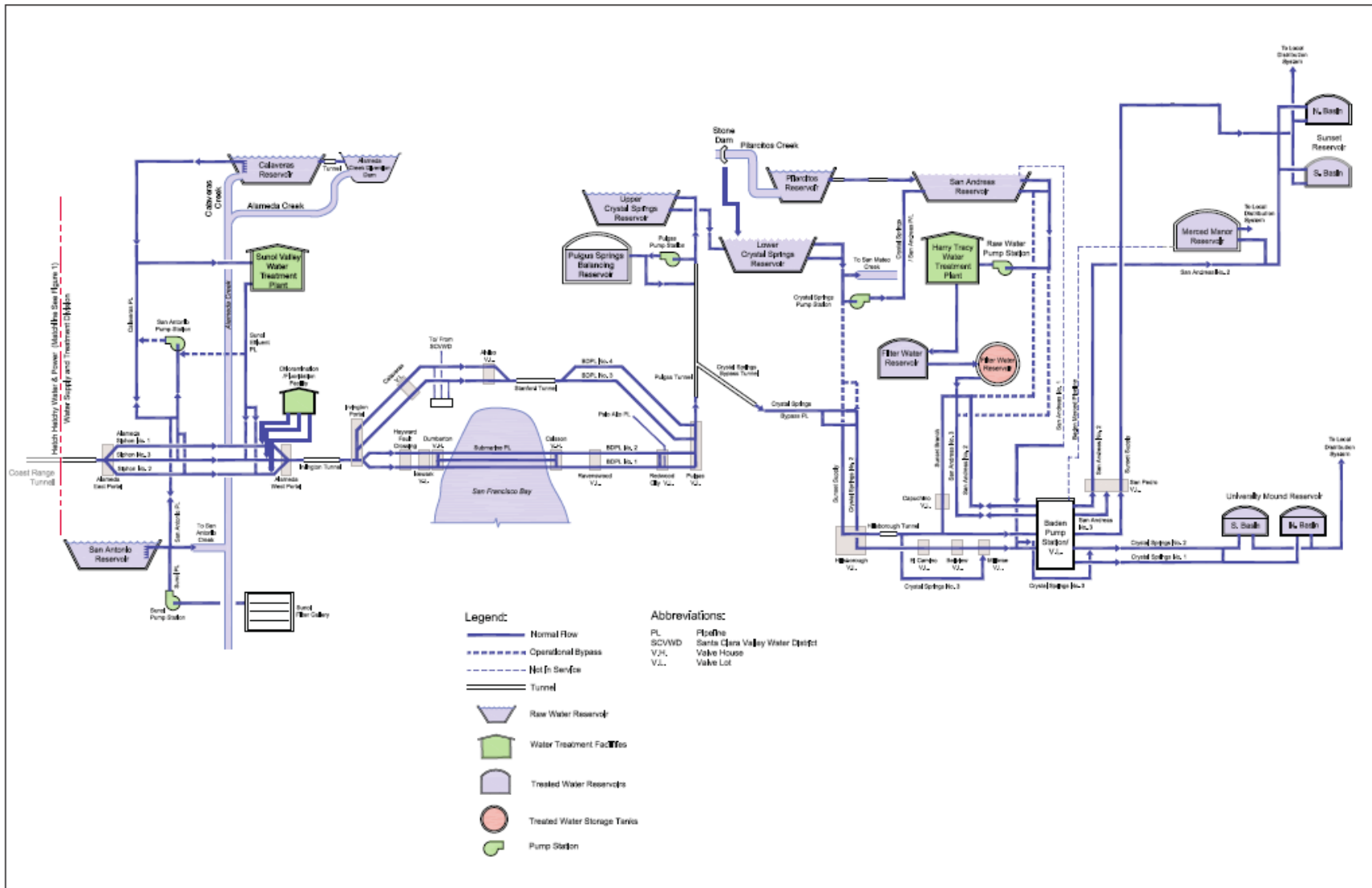

**Figure 2.3-1
SFPUC Wholesale and Retail Customers – Bay Area**

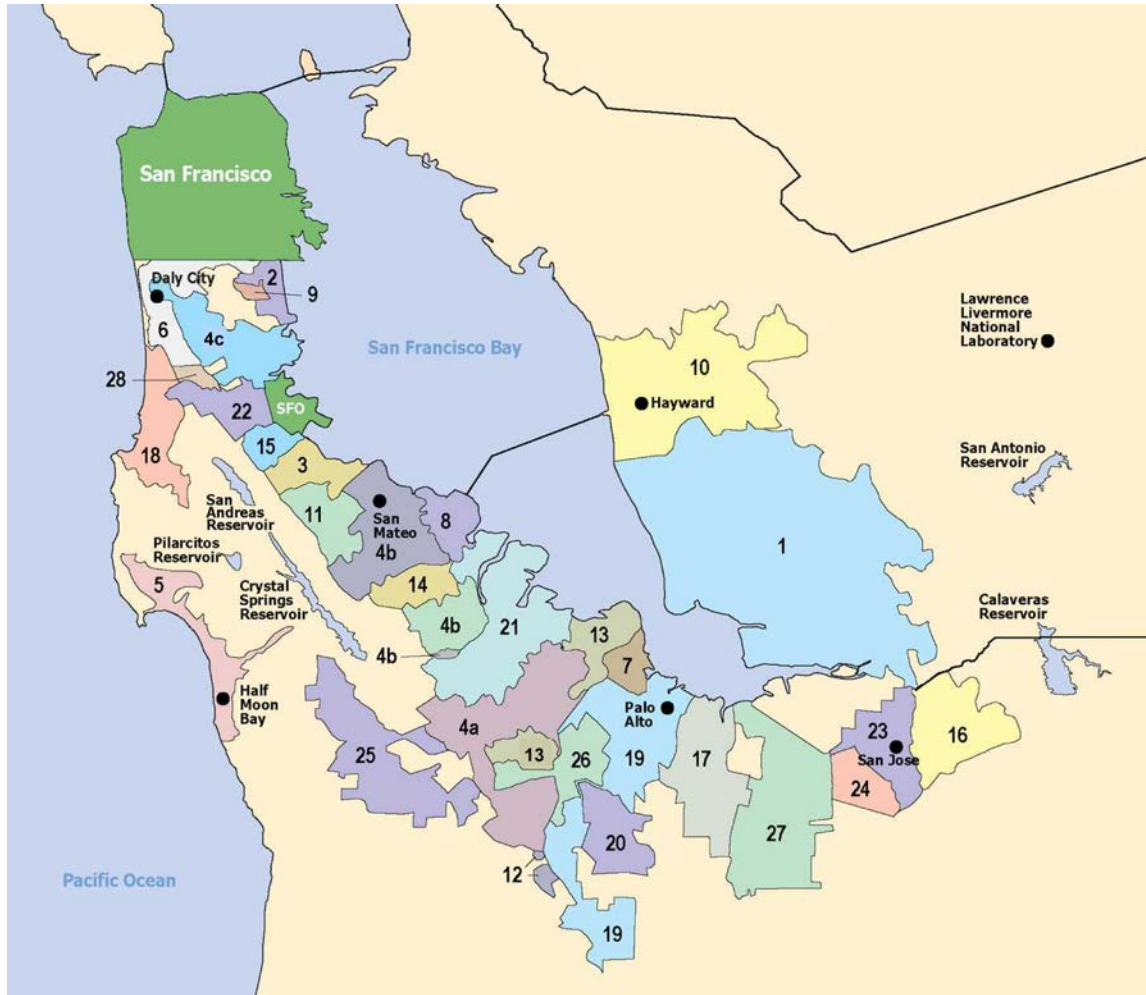

Map courtesy of BAWSCA website

#	SFPUC Wholesale Customer
1	Alameda County Water District
2	Brisbane, City of
3	Burlingame, City of
4a	CWS – Bear Gulch District
4b	CWS – Mid Peninsula District
4c	CWS – South San Francisco District
5	Coastside County Water District
6	Daly City, City of
7	East Palo Alto, City of
8	Esterero MID/Foster City
9	Guadalupe Valley MID
10	Hayward, City of
11	Hillsborough, Town of
12	Los Trancos County Water District
13	Menlo Park, City of
14	Mid-Peninsula Water District
15	Millbrae, City of
16	Milpitas, City of
17	Mountain View, City of
18	North Coast County Water District
19	Palo Alto, City of
20	Purissima Hills Water District
21	Redwood City, City of
22	San Bruno, City of
23	San Jose, City of (portion of north San Jose)
24	Santa Clara, City of
25	Skyline County Water District
26	Stanford University
27	Sunnyvale, City of
28	Westborough Water District

CWS - California Water Service (Company)
MID - Municipal Improvement District
Los Trancos Water District was purchased by California Water Service Company following the SFPUC studies published in 2004.

This illustration includes Los Trancos County Water District as a separate customer of the SFPUC. Subsequent to the publication of this illustration Los Trancos County Water District was purchased by California Water Service Company, which now results in 27 customers.

2.4 System Operations

Operation of the water system can be generally described by rules and strategies affecting the operation of the Bay Area system and rules and strategies affecting the operation of the Hetch Hetchy system. Although generally viewed separately, the two systems are integrally linked and are interdependent on each other.

SFPUC customer purchase requests are met with a combination of flows from the Hetch Hetchy system and the Bay Area system (sometimes referred to as the “local” system). The SFPUC operates the local reservoirs to conserve local watershed runoff, with diversions from the Hetch Hetchy system used to supplement the supply developed by the local reservoirs. The overriding operating goal of meeting system demand is to ensure that sufficient water is available year-round regardless of hydrologic conditions (drought or nondrought).

System operations and the amount of water delivered to customers vary throughout the year based on the seasonal demand and the availability of water. The availability of water for delivery to customers is affected by numerous factors, including meteorological and hydrologic conditions, the capacity and operating condition of physical facilities and infrastructure, and regulatory/institutional parameters that regulate and allocate the distribution of water from the various sources.

2.4.1 Normal System Operations

Under normal conditions there are sufficient water supplies from rainfall, snowmelt and storage such that water deliveries fulfill customer purchase requests and no systemwide water delivery reduction (rationing) is required.

Water in the Hetch Hetchy system (which includes Hetch Hetchy Reservoir, Lake Lloyd and Lake Eleanor) comes from a combination of rainfall and inflow from the melting snow pack in the Tuolumne River watershed. The majority (approximately 80 percent) of the inflow to the reservoirs occurs during the snowmelt period from April through July.

The SFPUC integrates the operation of its three major Tuolumne River reservoirs, Hetch Hetchy Reservoir, Lake Lloyd, and Lake Eleanor with the operation of the Water Bank Account in Don Pedro Reservoir. The operation of these reservoirs and the Water Bank Account is guided by two primary objectives: 1) conserve Hetch Hetchy Reservoir storage for diversion to meet the water purchase needs of the SFPUC customers, and 2) fulfill the Districts’ entitlement to Tuolumne River water under the Raker Act. There are also downstream release requirements prescribed for Hetch Hetchy Reservoir, Lake Lloyd, and Lake Eleanor.

The primary objective of Hetch Hetchy Reservoir operation is to maximize the volume of water stored in the reservoir (referred to as “carryover storage¹”) by July 1 of every year. After July 1, typically the end of snowmelt season, Hetch Hetchy Reservoir levels decline as diversions to the Bay Area exceed inflow to the reservoir.

Diversions from the Tuolumne River primarily originate from Hetch Hetchy Reservoir, and incidentally provide hydroelectric generation at Kirkwood and Moccasin Powerhouses. In general, large downstream releases immediately below Hetch Hetchy Reservoir are avoided by regulation of inflow and controlled smaller releases from the reservoir. In anticipation of snowmelt runoff, the SFPUC releases water from Hetch Hetchy Reservoir by sending water through Kirkwood Powerhouse, thus lowering the level of the reservoir and reducing the storage volume to allow room for inflow from snowmelt runoff. This reduction in storage normally begins in early winter as forecasts of snowmelt runoff become available. Drawdown of

¹ “Carryover storage is storage that is in a reservoir available for use in a succeeding period. For the SFPUC system, it is normally defined as the reservoir storage on July 1 of a given year. Carryover storage is a measurement of excess water captured when water is available from preceding periods, such as during the rainy season or wet years, and subsequently available for later use during the dry season and/or drought years.

reservoir storage is determined first by releases necessary to meet water demand and second by the capacity of Kirkwood Powerhouse. If determined necessary due to hydrologic conditions and reservoir storage capacity, additional controlled releases are made to the river.

Similar to the Hetch Hetchy Reservoir operation, the Lake Lloyd and Lake Eleanor system is operated to conserve reservoir inflow for both water supply and hydroelectric generation. Winter and spring operations rely on the occurrence and forecast of runoff that at times allows drawdown of reservoir storage. The drawdown of storage provides for inflow regulation and allows greater utilization of Holm Powerhouse. The water transfer capability from Lake Eleanor to Lake Lloyd through the Eleanor-Cherry Tunnel allows for the utilization of runoff from the Eleanor Creek watershed through Holm Powerhouse. Like Hetch Hetchy Reservoir, maximum carryover storage into the summer season is the primary objective for reservoir operations.

As previously stated, the primary operating strategy is to fill all Hetch Hetchy system reservoirs on or about July 1 of each year. Historically, this occurs in about 75 percent of the years, and generally by April 15 of each year the SFPUC can project the amount of water that will be stored in the system by July 1 of that year.

Operation of the Hetch Hetchy system is integrally linked with and dependent on the local watershed system. While the Hetch Hetchy system provides the majority of the water (about 85 percent), the production from the local watersheds is used first in system operations, and then supplemented with diversions from Hetch Hetchy. The local reservoirs are closer to customers and are operated to maximize emergency and drought protection storage.

San Antonio and Crystal Springs Reservoirs supplement the storage capacity of Hetch Hetchy Reservoir and are operated to maximize use of local resources for annual water deliveries, drought supply, and emergencies. Deliveries from Calaveras Reservoir can be offset by diversions from Hetch Hetchy. Carryover storage in these reservoirs is critical to support the drought preparedness of the water system.

When water in excess of customer demands is available from Hetch Hetchy Reservoir and there is available capacity in the transmission system and local reservoirs, the SFPUC diverts water from the Hetch Hetchy system for storage in local reservoirs, namely San Antonio Reservoir in Sunol Valley and Crystal Springs Reservoir on the Peninsula. This 'topping off' or replenishment operation develops carryover storage in the system. Replenishment of local reservoirs is part of the overall strategy for maximizing the available water supply. The operational goal is to replenish storage in local reservoirs during the end of the rainy season with a combination of inflow from the local watershed and water conveyed from the Hetch Hetchy system.

The SFPUC operates the local reservoir system to manage water captured from local watershed runoff and water conveyed from the Hetch Hetchy system. A primary objective of the local reservoir system is to conserve local watershed runoff for delivery. The local reservoir system's operation is seasonally driven. During the winter season, when rainfall and local watershed runoff occurs, the local reservoirs are managed to maintain sufficient available storage in the reservoirs in order to minimize spills from the reservoirs. In anticipation of or subsequent to storm events, runoff is conveyed to the Harry Tracy and Sunol Valley WTPs to maintain reservoir storage at winter storage objective levels. Towards the end of the winter as the likelihood of rain decreases, the reservoirs are operated to capture local watershed runoff with a goal of maximizing carryover storage in combination with Hetch Hetchy system storage.

During the summer, water drawn from the local reservoirs is minimized in order to preserve the carryover-storage water so it is available in the event of a disruption of flow from Hetch Hetchy or unplanned outages within the system. As the system demand increases past the capacity of flow from the Hetch Hetchy system, water is drawn from the local reservoirs to serve demands. At the beginning of fall, if the demand on local reservoir supplies has not drawn each reservoir down to its winter-time storage objective level, conveyance between the reservoirs, Hetch Hetchy flow rates, and treatment plant flow rates are adjusted to reach winter storage objective levels. However, if storage levels are below objectives, additional water may be conveyed from the Hetch Hetchy system to replenish a reservoir.

While the local watershed systems all have a common general operating strategy, there are unique operations within the different watersheds. As previously described, Calaveras Reservoir's inflow is supplemented by diversions from Alameda Creek through the Alameda Creek Diversion Dam and Tunnel. The typical operation of the diversion is to divert flow from Alameda Creek when it is available up to the capacity of the tunnel. Flow at the diversion site that exceeds the diversion capacity will flow over the diversion dam and contribute to flows in Alameda Creek downstream of the dam. Other than debris-flushing operations normally at the beginning and end of the rainy-season, the diversion tunnel will remain open. The exception to this operation is when Calaveras Reservoir is at or nearing its winter-time storage objective level. During these periods, the gates to the diversion tunnel are closed and all Alameda Creek flow passes the diversion dam. The closed-gate operation is more prevalent under the current DSOD restricted-operation condition of Calaveras Reservoir.

Pilarcitos Reservoir regulates water for delivery to Coastside County Water District (Coastside CWD) and for transfer into the system's San Andreas and Crystal Springs Reservoirs. Pilarcitos Reservoir regulates runoff into the reservoir for release to Pilarcitos Creek for rediversion at Stone Dam to Coastside CWD. Excess water in the watershed is diverted to the water system in the San Mateo Creek watershed. When runoff is greater than the water demand of Coastside CWD and the diversion and storage capacity of the system, the runoff will spill past Stone Dam and continue downstream in Pilarcitos Creek. At times when the water supply from Pilarcitos Reservoir and flow above Stone Dam is less than required by Coastside CWD, Coastside CWD can draw water from Crystal Springs Reservoir as a supplemental source.

None of the local system reservoirs currently have an instream release requirement immediately below its dam. Although the SFPUC has agreed with the California Department of Fish and Game to the maintenance of flows below Calaveras Reservoir, the restricted capacity of Calaveras Reservoir has delayed the implementation of the releases. Both San Mateo Creek, downstream of Crystal Springs Reservoir, and Pilarcitos Creek below Stone Dam, have limited channel capacity due to urban (San Mateo Creek) and agricultural (Pilarcitos Creek) encroachments. Therefore, both reservoirs are operated to minimize reservoir spills.

The water system is highly dependent on storage, both in the Sierras and locally in the Bay Area, to be able to serve water under a wide variety of meteorological/ hydrologic and operating conditions. During system upsets or when unusual water quality conditions occur in any of the reservoirs, the system includes a number of operational bypasses and backup facilities that allow the SFPUC to modify its normal operations and continue to meet water quality standards without interrupting service to its customers.

2.4.2 Operations during Drought Periods

System operations during drought periods require more complex planning and system management than during nondrought years. SFPUC drought planning uses as a backdrop the concepts of a "design drought" and "system firm yield." System firm yield is a measure of the amount of water that can be delivered to customers without shortages during all anticipated hydrologic sequences, including drought periods when rainfall, snowmelt, and/or streamflow conditions are substantially below normal for consecutive years. For planning purposes, the SFPUC uses a design drought that contemplates a more severe drought than historical events and evaluates the system firm yield assuming the system is experiencing the design drought. This premise is founded on experience that illustrates that drought sequences can get more extreme as our hydrologic record lengthens. Studies suggest that there is a 30 percent chance that the SFPUC system will experience a drought in the next 75 years equal to or more severe than the 1987-1992 drought. The design drought is a planning tool developed by the SFPUC used to anticipate and plan for drought; the SFPUC uses a design drought based on the hydrology of the six years of the worst sequential historical drought (1987-1992) plus the 2½ years of the 1976-1977 drought for a combined total of an 8½ year design drought sequence.

With no DSOD storage restriction on Calaveras Dam but with the DSOD restriction on Lower Crystal Springs Dam, the existing system firm yield of the Regional Water System is 226 mgd; however, due to

the operating restriction on Calaveras Dam imposed by the DSOD, the existing firm yield of the system is reduced to about 219 mgd. The Regional Water System currently (2005) provides an average normal-year systemwide delivery of about 265 mgd of water to customers on an annual basis. Since these current deliveries (265 mgd) are greater than the system firm yield (226 mgd under normal conditions or 219 under the DSOD restricted conditions), the Regional Water System cannot currently fully meet water deliveries to current customers during a prolonged drought. Reductions in deliveries (i.e., customer rationing) are required during drought periods.

The Regional Water System has experienced drought periods in the last 30 years: most notable are the droughts that occurred from 1976 through 1977, and from 1987 through 1992. During the 1987–1992 drought, even with the implementation of customer rationing, the amount of carryover storage in the regional system was more severely depleted than during any previous period of time, and the SFPUC had to adjust its normal operating procedures to avoid ‘running out of water’.

The 1987–1992 drought began at the end of the 1986 rainy season. Subsequent annual flows in the Tuolumne River were about 50 percent of average. The SFPUC’s entitlement to Tuolumne River flow was reduced to about 16 percent of the total river flow, and less than 50 percent of the normal amount of water delivered to customers was available from the river. As the drought progressed, the SFPUC developed and implemented short-term procedures to impose rationing on customers that resulted in a near 25 percent annual systemwide reduction in water deliveries. The extended drought resulted in the SFPUC adopting a mandatory rationing program from 1988 to 1989 and again from 1990 to 1993. Based on the experience of the 1987–1992 drought, the SFPUC modified its operational procedures with regard to drought planning.

The SFPUC system operations currently include a process for declaring a water shortage and a method for allocating reductions. The general protocol links total reservoir storage conditions to suggested delivery reductions. Each year, during the spring snowmelt period, the SFPUC evaluates the amount of total water storage throughout the system and determines if there is enough water available to serve full deliveries to customers within the context of the current year’s supply and the design drought. At a certain reservoir storage the SFPUC may impose delivery reductions. If reservoir storage becomes further depleted in a following year, the SFPUC may need to impose further delivery reductions. Currently with existing purchase requests there are three stages of delivery reduction: the first stage involves a 5 to 10 percent systemwide delivery reduction and is achieved by voluntary rationing; the second stage imposes an 11 to 20 percent systemwide delivery reduction and requires mandatory rationing; and, at the third stage of response, a 20 percent or greater systemwide delivery reduction would result in mandatory rationing with further reduced allocations. Prior to the initiation of any water delivery reductions, the SFPUC would hold a public meeting, open for public comment, to outline the water supply situation, the proposed water use reduction objectives, alternatives to water use reduction, and compliance monitoring methods.

3. Overview of Model

The SFPUC has developed a computerized mathematical model to simulate system operations. The model, known as the Hetch Hetchy/Local Simulation Model (HH/LSM), simulates the operation of San Francisco's Hetch Hetchy facilities, the Don Pedro Project, and the Bay Area reservoir, conveyance and treatment system.

HH/LSM is personal computer-based and is written in Fortran code, with spreadsheet input and output interfaces. The model accommodates modification to incorporate changes in operation assumptions or to allow the testing of proposed modifications to the operation of SFPUC or the Districts' facilities. Certain hydrologic and hydraulic parameters are "input driven" allowing the user to modify hydrology and the representation of physical characteristics such as reservoir capacity, preferred operational storage levels and water demands.

The model simulates system operations over the course of an 82-year sequential hydrologic period from July 1920 through September 2002. The model incorporates actual historic information about the hydrology (the amount of runoff as snowmelt and rainfall) that occurred in each year over the 82-year record for each of the three watershed areas under consideration: the Tuolumne River system, the Alameda Creek system and the Peninsula watershed system. This 82-year period includes many different types and sequences of actual hydrological events that have occurred ranging from flood events to droughts of different magnitude and duration. The long-term 82-year historical record is used in the model to represent the range of hydrologic conditions that could occur in the future. The model is used to assess how the system would perform as the result of an assumed system configuration and assumed operational objectives.

The model uses actual historic hydrology for the depiction of runoff within the watersheds. However, the model is not expected to explicitly replicate observed historical operations in all cases. The past operation of the system in an actual year will differ to some degree from the operations simulated by the model for that year as a result of many factors. These factors include the anomalies in past operation that required system operators to adjust operations throughout the year to respond to prevailing, changing conditions of weather, demand, and facility conditions (maintenance or unplanned facility outages). Also, the model does not incorporate the dynamic physical and institutional changes that have occurred to the system throughout history. Rather, the model is intended to depict operations with an assumed consistent set of systematic operational rules and objectives with a defined system configuration. This steady state of system configuration and operation is then evaluated over a broad range of hydrologic conditions. The utility of the model is the comparison of system performance that changes due to altering the assumptions for the operational rules and objectives, and system configuration.

The model simulates sequential hydrologic events on a monthly time step. That is, the model simulates the operation of facilities on a continuum, from one month to the next, one year to the next. This method of modeling allows the investigation of hydrologic events that vary in sequential duration, and which have varying distributions of runoff. This monthly time-step, with input and results depicted by monthly volumes of water, will not always adequately depict the day-to-day variation of operations, or an operational decision that can occur in less than monthly intervals. For instance, although the model will accurately depict that several thousand acre-feet of reservoir spill will occur from a reservoir in a month (e.g., 24,000 acre-feet in a month), the model results do not provide sufficient information regarding the daily magnitude or duration of the release during that month. A 24,000 acre-foot release during a month could occur as a constant release of 400 cfs per day, or it could represent an 800 cfs release during half of the days during a month. If such information is needed, additional supplemental analyses tiering from the HH/LSM results are required.

HH/LSM is used iteratively, adjusting model input after the review of results from a model study. The model simulates system performance and operations during the recurrence of historical hydrologic events. Parameters reviewed are typically the simulated delivery of water to SFPUC customers and reservoir levels and releases. Model inputs that affect model decisions are adjusted until a simulation achieves an accepted, or desired, performance of the scenario being modeled. Results from two or more

simulations are compared to illustrate the effects of alternative system objectives and requirements, operational assumptions and system configurations.

3.1 Water Demands

The water demands (purchase requests) of the SFPUC Regional Water System are modeled in HH/LSM. The geographical placement of these demands within the model is important for a representative depiction of system operations. Certain water demands of the SFPUC system are either fully dependent upon certain SFPUC facilities, or are most conveniently or historically served by certain facilities.

The SFPUC system water demand is defined by the summation of the individual water demands of the SFPUC's directly-served customers and the 27 wholesale customers. Almost all of these water demands are located in areas wrapping the San Francisco Bay from the city of Hayward in the east bay, southward to the city of Sunnyvale and portions of Santa Clara County, and then northward up the peninsula into the City and County of San Francisco. The model aggregates these demands into five demand centers (gradients): 1) City, 2) Crystal Springs, 3) San Andreas, 4) South Bay, and 5) Coastside. Figure 3.1-1 illustrates the general geographical delineation of the demand centers as incorporated into HH/LSM.

Each SFPUC system customer is either partially or fully assigned to a demand center for modeling purposes. Lawrence Livermore Laboratory and the directly-served customers in Sunol Valley are assigned to the South Bay demand center; Suburban municipal, commercial and single-family accounts are divided among the South Bay and Crystal Springs demand centers; and the San Francisco Airport is assigned to the Crystal Springs demand center. Groveland Community Services District and other Tuolumne River Basin demands are modeled within the Hetch Hetchy logic of HH/LSM. The monthly pattern of demands for each customer reflects a monthly distribution of historical deliveries, and the individual customer's contribution to a demand center's aggregated total demand shape is weight-averaged.

A single level of average annual water demand, e.g., 265 mgd for a current system simulation, is assumed for all years of the simulation. This average annual water demand is distributed among the demand centers and shaped monthly according to the protocols just described.

3.2 Water Availability and System Performance Studies

The SFPUC quantifies water availability through the performance of two types of analyses. Each of these analyses provides a statement of the ability of the SFPUC Regional Water System to deliver water. The first type of analysis defines the system firm yield of the SFPUC system. As stated above, system firm yield is a measure of the amount of water that can be delivered to customers without shortages during all anticipated hydrologic sequences. System firm yield is the average annual water delivery that can be sustained without shortage throughout the 8½ year design drought. The second type of analysis identifies the reliability of the SFPUC Regional Water System during a recurrence of a long record of hydrologic conditions. The hydrologic record used for these analyses is the 82-year sequence of hydrology previously described. A system firm yield study will identify the rules of operation and delivery rationing that maximizes water deliveries during the design drought. Those rules are then applied within a system performance study to identify the reliability of water deliveries and system operation over a long sequence of hydrology.

3.2.1 System Firm Yield Study

The system firm yield study is focused on operations and water deliveries during drought sequences. As described previously, the SFPUC uses a design drought that contemplates a more severe drought than historical events, and defines the system firm yield assuming the system is experiencing the design drought. To quantify the system firm yield, operation of the SFPUC system is tested during the design

**Figure 3.1-1
SFPUC Water Demand Grouping for Modeling**

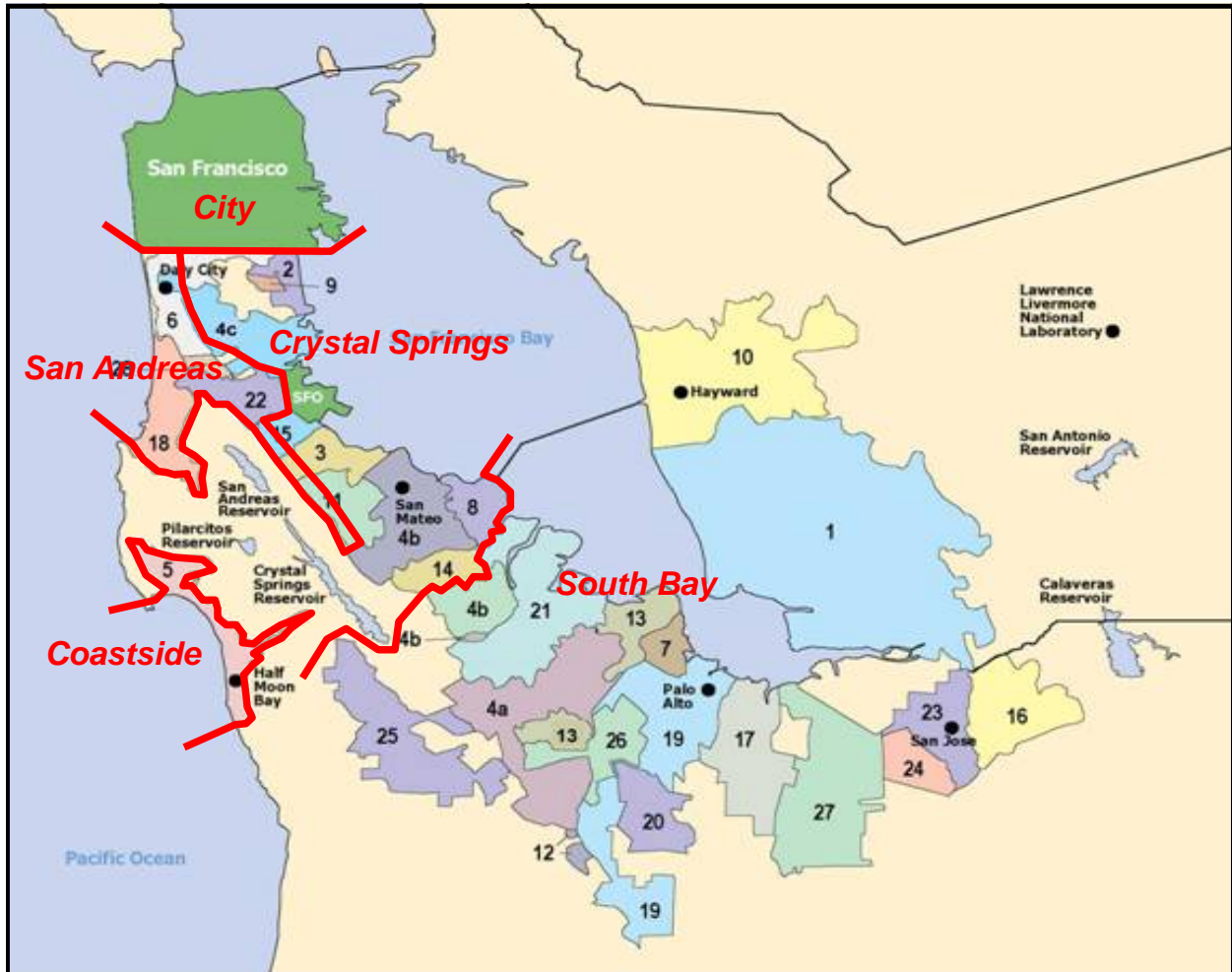

#	SFPUC Wholesale Customer	#	SFPUC Wholesale Customer
1	Alameda County Water District	14	Mid-Peninsula Water District
2	Brisbane, City of	15	Millbrae, City of
3	Burlingame, City of	16	Millipitas, City of
4a	CWS - Bear Gulch District	17	Mountain View, City of
4b	CWS - Mid Peninsula District	18	North Coast County Water District
4c	CWS - South San Francisco District	19	Palo Alto, City of
5	Coastside County Water District	20	Purissima Hills Water District
6	Daly City, City of	21	Redwood City, City of
7	East Palo Alto, City of	22	San Bruno, City of
8	Estero MID/Foster City	23	San Jose, City (portion of North San Jose)
9	Guadalupe Valley MID	24	Santa Clara, City of
10	Hayward, City of	25	Skyline County Water District
11	Hillsborough, Town of	26	Stanford University
12	Los Tancos County Water District*	27	Sunnyvale, City of
13	Menlo Park, City of	28	Wesborough Water District

* Los Tancos County Water District is now a part of California Water Service Company

drought with increasing levels of delivery and varying protocols for rationing until useable reservoir storage is depleted at the end of the design drought. These deliveries are the metric of the amount of water available after satisfying all of the other commitments of the system such as required stream releases and flow obligations to the Districts. Since the level of delivery (percentage of full purchase request) can vary year to year within the design drought, the system firm yield is expressed as the average annual water delivery that can be sustained throughout the entire 8½ year design drought. The analysis that defines system firm yield simulates system reservoir storage being fully depleted at the end of the design drought sequence.

3.2.2 Protocol for Modeling System Drought Response and Shortage Levels

As described above, SFPUC system operations currently include a process for declaring a water shortage and a method for allocating reductions. The protocol links total reservoir storage conditions to suggested delivery reductions. The model mimics this protocol simulating drought related system actions in response to simulated total reservoir storage projected for July 1 of each year. For the current system, modeled drought response occurs as three levels of curtailed (rationed) deliveries, with each successively more severe rationing level occurring as total system reservoir storage is depleted. Modeling results for the design drought period provide the relationship between total system reservoir storage and the level of rationing. The severity of rationing, the frequency of rationing and total system reservoir storage “triggers” are iteratively tested until a viable operation and systematic and acceptable water delivery rule occurs.

Currently with existing purchase requests, there are three modeled stages of drought response: the first stage models a 10 percent systemwide delivery reduction; the second stage models a 20 percent systemwide delivery reduction; and, at the third stage a 25 percent systemwide delivery reduction occurs.

HH/LSM has the functionality to incorporate four levels of drought response. The fourth level of response is also triggered by total system reservoir storage, and can be used as a “switch” to activate a non-rationing form of water supply action. This “level” has been used to activate water purchases, groundwater retrieval, and desalination production prior to, or coincidental to initiating water delivery reductions. The model is also capable of monitoring additional system parameters such as Hetch Hetchy Reservoir storage to additionally constrain system deliveries. The model will make its decision to constrain (or not constrain) system deliveries each year based on the total system reservoir storage, and applies the level of action for a complete year running from July through the following June. Within a year of operation, the action level will be unset when total system reservoir storage reaches a user-specified level, which mimics the relaxation of rationing when the system has recovered from drought conditions.

3.3 Model Outputs

HH/LSM provides a robust array of monthly time-step results for each model simulation. Once the operation of the system is modeled under a particular set of assumptions, the model provides output information about how the system performs under that scenario in terms of water in reservoir storage, releases and stream flows, water deliveries, and other parameters associated with the system’s reservoirs, conveyance facilities and treatment plants. The model provides information representing monthly volumes of water, although certain parameters have been converted to flow rates. Table 3.3-1 lists some of the most salient output information provided by the model.

3.4 Generalized Model Representation

HH/LSM mimics the operation of the SFPUC Regional Water System, as that operation would vary from season to season and year to year as hydrology changes. A constant level of annual system water demand (purchase request) is assumed each year of simulated operation. The full demand will be met each year except during periods when depleted system storage triggers a reduction from full deliveries. The amount of water demand met by simulated diversions from Hetch Hetchy is the residual amount of water demand that is not met from the Bay Area water supplies.

The water system is depicted as a linked series of inflows, reservoirs, conveyance routes and areas of water demand. The two major groups of logic components of the model separately represent the system as the Hetch Hetchy system and the Bay Area system. The two groups of logic components are joined by the representation of the San Joaquin Pipelines. Diversions from Hetch Hetchy to the Bay Area are dependent on an interaction between the water demand, local Bay Area water supplies and system operation, and the total system reservoir storage of the SFPUC system.

**Table 3.3-1
Hetch Hetchy/Local System Model Outputs**

Feature	Output Parameter
Calaveras (MG)	Calaveras Reservoir Storage
	Calaveras Reservoir Inflow from Arroyo Hondo
	Calaveras Reservoir Inflow from Upper Alameda Creek
	Calaveras Reservoir Release to San Antonio Reservoir
	Calaveras Reservoir Release to SVWTP
	Calaveras Reservoir Release to Calaveras Creek
	Calaveras Reservoir Spill to Calaveras Creek
	Calaveras Reservoir Evaporation
San Antonio (MG)	San Antonio Reservoir Storage
	San Antonio Reservoir Inflow from San Antonio Creek
	San Antonio Reservoir Inflow from Calaveras Reservoir/SJPL
	San Antonio Reservoir Release to Sunol Valley WTP
	San Antonio Reservoir Release to San Antonio Creek
	San Antonio Reservoir Spill to San Antonio Creek
	San Antonio Reservoir Evaporation
Crystal Springs (MG)	Crystal Springs Reservoir Storage
	Crystal Springs Reservoir Inflow from San Mateo Creek
	Crystal Springs Reservoir Inflow from San Andreas Reservoir
	Crystal Springs Reservoir Inflow from BDPL
	Crystal Springs Reservoir Pumping to San Andreas Reservoir
	Crystal Springs Reservoir Pumping to Coastside CWD
	Crystal Springs Reservoir Release to San Mateo Creek
	Crystal Springs Reservoir Spill to San Mateo Creek
	Crystal Springs Reservoir Evaporation
San Andreas (MG)	San Andreas Reservoir Storage
	San Andreas Reservoir Inflow from Watershed
	San Andreas Reservoir Inflow from Crystal Springs, San Mateo Creek & Pilarcitos
	San Andreas Reservoir Release to Harry Tracy WTP
	San Andreas Reservoir Release to San Mateo Creek
	San Andreas Reservoir Spill to San Mateo Creek
	San Andreas Reservoir Evaporation
Pilarcitos (MG)	Pilarcitos Reservoir Storage
	Pilarcitos Reservoir Inflow
	Pilarcitos Reservoir Release to San Andreas Reservoir
	Pilarcitos Reservoir Release for Stone Diversion to CCWS
	Pilarcitos Reservoir Pre-Release to Pilarcitos Creek
	Pilarcitos Reservoir Spill to Pilarcitos Creek
	Pilarcitos Reservoir Evaporation
Stone Dam (MG)	Stone Dam Inflow (Accretion)
	Stone Dam Release to Coastside CWD
	Stone Dam Release to Crystal Springs Reservoir
Reservoir Storage (MG)	Total Reservoir Storage – East Bay
	Total Reservoir Storage – Peninsula
	Total Local Storage
	Maximum Targeted Total Local Storage

Table 3.3-1 (continued)
Hetch Hetchy/Local System Model Outputs

Feature	Output Parameter
Demand (MGD)	Delivery to South Bay Demand Center
	Delivery to Crystal Springs Demand Center
	Delivery to San Andreas Demand Center
	Delivery to In-City Demand Center
	Total Delivery to Demand Centers (not including Coastside CWD)
Demand (MG)	Delivery to South Bay Demand Center
	Delivery to Crystal Springs Demand Center
	Delivery to San Andreas Demand Center
	Delivery to In-City Demand Center
	Total Delivery to Demand Centers (not including Coastside CWD)
San Joaquin Pipelines (SJPL)	SJPL Flow – MG
	SJPL Flow – MGD
SJPL (MG)	SJPL Flow to Crystal Springs Reservoir - MG
	SJPL Flow to San Antonio Reservoir – MG
West Basin Reservoir (MG)	Beginning of Month Storage
	West Basin Reservoir - Input Resulting from San Andreas Gradient Deliveries
	West Basin Reservoir - Input Resulting from Crystal Springs Gradient Deliveries
	End of Month Storage
Desalination Project (MG)	Input from Desalination Project
Treatment Plant Delivery (MGD)	Calaveras Reservoir Flow to Sunol Valley WTP
	San Antonio Reservoir Flow to Sunol Valley WTP
	Sunol Valley WTP Production
	Harry Tracy WTP Production
Unimpaired Inflow (acre-feet)	Inflow to Hetch Hetchy Reservoir
	Inflow to Cherry Reservoir
	Inflow to Eleanor Reservoir
	Unregulated Flow below Hetch Hetchy Reservoirs
End-of-month Storage (acre-feet)	Hetch Hetchy Reservoir Storage
	Cherry Reservoir Storage
	Eleanor Reservoir Storage
	Don Pedro Water Bank Account Storage
	Don Pedro Reservoir Storage
	Total Up-Country Reservoir Storage
	Total Hetch Hetchy System Storage
Releases (acre-feet)	Hetch Hetchy Reservoir Release to Stream
	Hetch Hetchy Reservoir Release to Canyon Tunnel
	Lake Lloyd Release to Stream
	Lake Lloyd Release to Holm Powerhouse
	Lake Eleanor Release to Stream
	Lake Eleanor Tunnel to Lake Lloyd
Evaporation (acre-feet)	Hetch Hetchy Reservoir
	Lake Lloyd
	Lake Eleanor
SJPL (acre-feet)	SJPL Flow from Lower Cherry Aqueduct
	Total SJPL

Table 3.3-1 (continued)
Hetch Hetchy/Local System Model Outputs

Feature	Output Parameter
Precipitation (inches)	Hetch Hetchy Precipitation – Accumulated
Power Production (MWh)	Moccasin PH
	Kirkwood PH
	Holm PH
	Total
Unimpaired Runoff (acre-feet)	Unimpaired Runoff at La Grange
	Districts' Rights and Entitlements
	Unimpaired Runoff Available to San Francisco
Don Pedro Operations (acre-feet)	Inflow
	Storage
	Don Pedro Reservoir Flood Control Limit
	Don Pedro Reservoir Evaporation (San Francisco)
	Total Don Pedro Reservoir Evaporation
	Don Pedro Reservoir Power – MWh
	Total MID Diversion at LaGrange
	Total TID Diversion at LaGrange
	La Grange Minimum Release Requirement
	Total La Grange Release to River
	Total Release from Don Pedro Reservoir
	Water Bank Account – (acre-feet)
Water Bank Account Maximum	
Transfer to Water Bank Account	
Miscellaneous	SFPUC Shortage Level
	Hetch Hetchy Minimum Stream Release (acre-feet)

All of the system's reservoirs are guided by an underlying objective to conserve inflow for diversions and required releases. Underlying the Hetch Hetchy system operation are the regulatory and institutional obligations that necessitate releases below SFPUC reservoirs. The model will only release the minimum amount of required flow unless otherwise desired. The model allows the user to select a desired level of water supply certainty. Through model input, the user can choose an operation that varies from making no discretionary releases to the Tuolumne River (e.g., for power) that might result in a lessening of water supply during drought, to making discretionary releases to the Tuolumne River based on a risk assessment of anticipated runoff.

Diversions from Hetch Hetchy Reservoir will incidentally provide hydroelectric generation at Kirkwood and Moccasin powerhouses. The model simulates the power operation of these facilities in addition to simulating the operation of Holm Powerhouse which develops hydroelectric generation from releases from the Lake Lloyd and Lake Eleanor system.

Water that is released from SFPUC reservoirs and not diverted to municipal use, and runoff that originates below SFPUC reservoirs flows to Don Pedro Reservoir. HH/LSM simulates the Districts' operation of Don Pedro Reservoir including the simulation of canal diversions, flood control operations, and releases to meet flow requirements below La Grange Dam. The model also simulates the accounting for the Water Bank Account in Don Pedro Reservoir.

The group of model components that represent the Bay Area system integrates with the Hetch Hetchy operation, and determines the call for water from Hetch Hetchy. Numerous operational constraints are incorporated into the local system's modeled operation including considerations for limited downstream channel conveyance capacity, treatment plant capacity, and water transmission capability. In general, the Bay Area system is modeled to conserve local Bay Area watershed runoff and when possible, to conserve Tuolumne River water resources. Seasonal storage targets for each Bay Area reservoir have been developed. The seasonal process (storage targets) provides empty reservoir storage space prior to the winter season. This reservoir space is filled with Bay Area watershed runoff and Tuolumne River water by late spring in order to carry maximum reservoir storage into the summer season. The reservoir storage targets incorporate several considerations including downstream channel capacity constraints (Crystal Springs Reservoir) and treatment plant capacity constraints which limit the rate of use of Bay Area reservoir waters.

4. Model Inputs

Numerous user-defined data and parameters provide HH/LSM the information to define and perform a study. This section describes the inputs to HH/LSM. The inputs are grouped into subsections: Hydrology, Facilities, Minimum Release Requirements, and Operations.

4.1 Hydrology

This section describes the basic hydrologic data that are included in operation simulations. Regardless of operational assumptions these data remain constant among simulations providing the underlying hydrology for the system. These basic data represent inflows to reservoirs and other required basic hydrologic information.

4.1.1 Precipitation

As will be described later, minimum stream releases below Hetch Hetchy Reservoir depend, in part, on the annual accumulated precipitation at Hetch Hetchy Reservoir. Table 4.1.1-1 illustrates the accumulated precipitation at Hetch Hetchy Reservoir for each month of the simulation period. This is the only precipitation parameter used for modeling the system.

4.1.2 Unimpaired Runoff and Reservoir Inflows

Underlying the regulated flow within the system is the runoff that naturally occurs due to precipitation and snowmelt. Regardless of the ability of San Francisco and the Districts to regulate this runoff, natural runoff will only vary due to the day-to-day, season-to-season and year-to-year variability of weather. The historical, naturally occurring runoff at the various locations of interest was determined by several methods of analysis. The methods of analysis used to estimate runoff varied among the locations due to the availability of recorded data or the nature of the data item being determined. Common to all the developed data is the length of record used during the simulation of operations.

4.1.2.1 Unimpaired Runoff at La Grange Dam

A fundamental hydrologic parameter of the Tuolumne River is the calculated unimpaired runoff at La Grange Dam. These data represent the amount of flow which would occur at this location if San Francisco and District facilities did not regulate or divert the naturally occurring runoff in the basin. The annual unimpaired runoff at La Grange Dam for the 1921-2002 hydrologic period has ranged from a minimum of 381,900 acre-feet (1977) to 4,631,400 acre-feet (1983). The average annual unimpaired runoff is computed to be 1,850,100 acre-feet.

Table 4.1.2.1-1 depicts the record of unimpaired runoff at La Grange Dam for the hydrologic period October 1921, through September 2002.

4.1.2.2 Inflow to Hetch Hetchy Reservoir

Tributaries upstream of Hetch Hetchy Reservoir are essentially in their natural state, with few diversions or regulation occurring. The record of inflow for Hetch Hetchy Reservoir has been developed by use of actual stream measurements (prior to construction of Hetch Hetchy Reservoir), and subsequently the calculation of inflow based on the operation records of Hetch Hetchy Reservoir. Table 4.1.2.2-1 depicts the record of inflow for Hetch Hetchy Reservoir. Annual inflow has ranged from a low of 206,400 acre-feet (1977) to a maximum of 1,697,700 acre-feet (1983). The average annual inflow to Hetch Hetchy Reservoir is 749,600 acre-feet.

Table 4.1.1-1

Accumulated Precipitation at Hetch Hetchy Reservoir (Inches – Beginning October 1)

Water Year	Oct	Nov	Dec	Jan	Feb	Mar	Apr	May	Jun	Jul	Aug	Sep
1921	6	11	16	27	31	35	36	39	39	39	39	39
1922	1	1	11	15	21	28	28	31	31	31	31	31
1923	2	5	13	18	19	19	28	29	30	31	31	33
1924	1	2	4	7	9	13	15	15	15	15	15	15
1925	5	8	14	16	29	35	39	42	43	43	44	45
1926	3	5	7	11	19	20	25	26	26	27	27	27
1927	0	12	13	18	28	32	36	37	38	38	38	38
1928	5	11	15	17	20	31	34	35	36	36	36	36
1929	0	3	7	8	12	18	22	23	26	26	26	27
1930	0	0	4	11	15	19	23	25	25	25	25	27
1931	1	5	5	10	13	15	18	20	22	22	22	22
1932	1	5	17	22	30	31	33	37	38	38	38	38
1933	0	0	3	11	13	16	17	20	21	22	22	22
1934	1	2	8	12	19	19	20	21	23	23	23	24
1935	2	8	12	22	25	31	40	41	41	41	41	41
1936	2	4	6	14	31	32	35	36	38	38	38	38
1937	1	2	11	16	28	34	36	36	36	37	37	37
1938	1	4	14	20	34	47	52	54	55	56	56	57
1939	5	7	9	13	16	21	22	24	25	25	25	28
1940	5	6	7	20	30	37	38	39	39	39	39	39
1941	3	4	19	25	32	37	42	44	44	44	44	44
1942	2	6	19	23	29	31	37	41	41	41	41	42
1943	1	8	13	23	26	37	39	40	41	41	41	41
1944	2	5	7	12	18	22	27	28	29	29	29	29
1945	2	11	15	16	26	33	34	36	37	37	38	38
1946	6	12	22	23	26	33	33	35	35	36	36	36
1947	3	11	15	17	19	23	25	27	27	27	27	27
1948	5	7	8	10	14	22	30	32	33	33	33	33
1949	1	2	8	11	16	23	23	26	26	26	26	26
1950	0	4	6	16	18	24	29	30	30	30	30	30
1951	5	20	32	37	41	44	46	48	49	49	49	49
1952	2	7	19	29	35	42	46	47	48	48	48	49
1953	0	2	11	17	17	20	24	28	29	31	31	31
1954	1	4	6	13	19	27	30	31	33	33	33	33
1955	0	3	11	16	18	20	24	26	26	26	26	26
1956	0	7	30	41	43	44	48	52	52	52	52	53
1957	3	3	4	9	14	20	23	28	29	29	29	29
1958	2	5	10	16	24	35	40	41	44	44	44	46
1959	0	2	3	9	17	18	21	22	22	23	23	27
1960	0	0	1	5	13	19	21	22	22	22	22	22
1961	1	6	9	11	13	18	20	22	23	23	24	25
1962	1	4	7	9	24	29	30	31	31	32	32	33
1963	2	3	5	11	19	25	33	36	39	39	39	40
1964	2	9	10	14	14	18	20	23	25	25	25	25
1965	2	9	26	31	33	36	40	41	41	41	45	45
1966	1	12	16	18	21	21	24	25	25	26	26	26
1967	0	7	15	23	24	33	46	47	49	49	49	50
1968	0	3	6	10	15	18	19	20	20	20	21	21
1969	3	9	18	37	46	49	54	54	56	56	56	56
1970	4	6	10	24	27	30	33	33	35	35	35	35
1971	1	10	18	20	21	25	27	30	30	30	30	31
1972	1	6	15	17	19	19	23	23	24	24	24	25
1973	1	7	12	19	28	33	34	35	35	35	36	36
1974	3	11	19	24	25	33	38	38	38	38	38	38
1975	3	5	9	12	22	30	36	36	37	39	41	41
1976	7	8	9	9	13	16	18	20	20	20	21	22
1977	2	3	3	5	8	9	10	14	16	16	16	17
1978	1	6	16	26	37	46	55	55	56	56	56	60
1979	0	4	7	19	28	33	35	37	37	37	37	37
1980	3	7	12	28	41	46	48	51	51	51	51	51
1981	1	2	5	13	16	23	25	27	27	27	27	27
1982	5	13	21	29	35	44	50	50	52	52	52	56
1983	6	16	25	35	45	61	68	69	70	70	70	73
1984	1	15	27	27	32	35	37	38	40	40	40	40
1985	4	13	14	15	18	24	25	25	26	26	26	28
1986	3	9	13	17	34	41	43	44	44	45	45	47
1987	0	0	1	5	9	13	15	16	16	17	17	17
1988	3	7	11	16	17	17	21	23	24	24	24	24
1989	0	7	13	13	17	26	28	29	30	30	30	30
1990	0	1	7	12	14	16	19	19	20	20	20	21
1991	1	2	4	4	5	21	22	24	25	25	25	25
1992	4	6	8	10	16	19	19	20	22	25	25	25
1993	4	4	12	23	31	35	37	38	40	40	40	40
1994	2	4	6	8	13	15	18	20	20	20	20	21
1995	2	11	15	30	30	47	55	60	61	61	61	61
1996	0	0	8	17	27	31	35	39	40	40	41	41
1997	2	12	27	44	44	45	46	47	48	48	48	48
1998	1	5	9	21	35	42	46	53	56	56	56	58
1999	0	5	9	18	27	29	32	33	34	34	34	34
2000	1	4	4	14	26	29	33	36	38	38	38	39
2001	4	5	6	12	17	20	26	26	26	27	27	27
2002	1	8	18	20	22	26	28	31	31	31	31	31
Avg (21-02)	2	6	12	18	23	28	32	34	34	35	35	35

**Table 4.1.2.1-1
Unimpaired Flow at La Grange Dam (Acre-feet)**

Water Year	Oct	Nov	Dec	Jan	Feb	Mar	Apr	May	Jun	Jul	Aug	Sep	WY Total
1921	41,076	53,296	69,546	196,199	155,944	231,774	254,350	442,185	458,320	95,173	13,498	6,563	2,017,924
1922	5,796	6,084	54,599	71,722	189,459	181,279	260,346	717,525	751,926	194,559	27,217	10,393	2,470,905
1923	10,604	31,609	123,931	113,587	79,515	113,105	265,739	521,296	319,127	157,837	27,338	22,266	1,785,954
1924	28,512	13,624	13,757	25,335	41,623	37,857	138,855	209,395	16,850	16,810	-1,890	-3,917	536,811
1925	14,660	47,909	51,045	44,255	227,090	165,638	350,329	538,439	352,379	111,858	22,649	5,853	1,932,104
1926	15,116	16,209	32,763	18,952	100,584	127,438	382,302	303,784	89,230	18,914	3,253	1,377	1,109,922
1927	5,482	74,075	60,016	63,203	223,125	159,717	351,499	454,088	476,184	146,291	24,589	13,119	2,051,388
1928	15,342	87,011	44,108	51,263	82,207	343,418	263,768	447,773	152,652	27,622	7,301	2,563	1,525,028
1929	-543	5,788	18,115	19,057	40,449	99,404	148,100	378,119	224,686	40,740	4,568	-9,271	969,212
1930	1,860	1,236	23,026	39,027	70,064	146,572	245,919	274,802	286,227	48,843	9,989	-970	1,146,595
1931	9,023	20,372	10,715	26,087	44,485	66,268	154,028	209,322	49,010	10,219	940	1,805	602,274
1932	1,680	6,042	93,661	79,368	240,198	171,588	245,048	524,154	532,657	175,844	31,968	12,044	2,114,252
1933	5,718	3,197	10,858	26,901	31,476	82,585	170,939	250,816	426,145	75,096	16,066	4,540	1,104,337
1934	-292	7,958	40,848	64,905	89,980	150,248	186,390	149,036	95,092	12,073	6,109	4,566	806,913
1935	11,183	47,622	51,951	105,903	107,268	136,887	465,489	530,698	511,475	109,587	10,726	4,070	2,102,858
1936	11,591	19,587	18,155	104,787	351,981	207,525	392,941	520,229	390,216	122,450	17,810	2,924	2,160,196
1937	4,318	8,610	27,322	31,434	273,903	209,510	295,599	633,901	399,410	91,359	16,854	4,798	1,997,018
1938	9,154	18,758	312,561	101,938	322,739	424,839	422,380	720,160	711,600	305,191	55,468	19,537	3,424,325
1939	40,248	43,485	36,718	42,594	59,919	144,114	281,901	216,036	74,337	17,344	7,484	16,834	981,014
1940	44,943	16,616	20,248	226,488	250,001	344,136	324,857	271,098	347,501	54,156	10,755	2,015	2,212,814
1941	11,306	15,005	129,055	115,450	218,996	260,080	279,587	662,676	534,437	224,055	30,489	8,189	2,489,325
1942	7,038	37,559	161,534	164,811	142,433	148,707	336,994	471,991	597,584	253,443	30,160	3,279	2,355,533
1943	5,053	86,407	92,847	246,319	163,756	371,921	385,171	494,527	352,890	140,897	24,802	5,205	2,369,795
1944	11,602	15,626	20,933	42,727	80,413	135,224	164,620	455,797	267,180	87,627	11,203	2,362	1,295,314
1945	9,122	89,046	81,309	55,601	304,843	164,410	284,264	455,072	462,260	163,056	16,762	-1,174	2,084,571
1946	60,306	98,295	207,738	118,911	69,889	155,802	347,842	488,513	264,554	56,169	7,927	3,364	1,879,310
1947	16,070	64,001	76,715	41,875	80,221	136,057	192,224	352,497	110,745	20,882	-601	2,884	1,093,570
1948	38,204	28,149	17,171	39,677	25,862	73,007	220,653	436,245	433,764	87,725	5,173	2,475	1,408,105
1949	5,147	8,211	17,768	19,899	39,117	123,239	318,247	436,422	240,367	29,469	4,511	3,717	1,466,114
1950	3,915	14,216	13,418	77,458	124,323	128,314	329,129	467,436	319,386	62,240	6,514	-817	1,545,532
1951	24,439	521,560	508,994	159,244	138,911	168,700	253,809	372,863	256,731	60,101	9,570	272	2,475,194
1952	9,023	30,850	121,412	218,693	147,758	239,843	466,417	791,330	594,182	291,864	54,091	16,905	2,982,368
1953	8,666	11,861	53,056	145,087	63,531	106,649	269,599	259,519	414,411	169,821	17,793	5,397	1,525,390
1954	7,325	17,169	24,196	41,891	101,379	213,203	349,174	447,548	185,141	37,924	3,082	1,154	1,429,186
1955	4,062	15,380	49,991	66,700	61,166	82,395	143,952	366,448	292,177	39,300	924	1,204	1,123,699
1956	3,965	12,962	649,624	431,296	156,099	178,525	281,786	559,662	581,816	244,241	40,675	12,165	3,152,816
1957	21,366	24,262	24,202	35,042	123,753	153,535	172,495	379,989	404,981	67,160	8,739	2,041	1,417,565
1958	11,296	18,389	48,032	58,124	176,735	256,766	425,004	761,395	579,215	231,899	54,873	16,633	2,638,361
1959	5,991	5,831	5,234	78,639	116,210	119,022	224,043	231,483	138,833	18,216	1,496	44,721	989,619
1960	5,320	9,533	12,301	25,202	119,381	149,498	238,389	303,406	162,351	16,064	5,798	5,141	1,052,384
1961	5,389	15,656	32,686	18,660	46,554	71,391	164,818	219,808	122,305	18,756	12,514	3,836	732,373
1962	4,996	8,029	23,685	23,869	233,312	139,023	389,026	362,479	445,575	116,886	14,063	4,992	1,765,935
1963	17,284	8,747	29,449	93,094	308,729	112,197	247,529	533,657	463,438	179,127	31,868	16,034	2,041,153
1964	17,677	104,941	48,020	53,546	51,804	75,267	169,186	323,074	225,025	41,217	12,351	8,158	1,130,266
1965	8,854	52,247	517,140	288,696	141,060	140,884	326,033	448,977	476,527	227,611	87,414	22,931	2,398,374
1966	7,436	129,568	88,854	77,750	74,930	146,418	298,544	354,857	86,348	22,324	9,308	9,759	1,306,096
1967	7,083	67,331	221,595	134,965	115,037	306,311	289,535	648,922	743,532	472,504	77,528	20,259	3,104,602
1968	9,935	11,141	31,620	47,230	134,487	122,791	187,492	287,671	141,007	18,655	10,028	4,558	1,006,615
1969	12,657	80,850	81,259	577,549	285,997	263,459	489,687	960,266	716,378	316,146	54,805	13,182	3,852,235
1970	38,505	39,314	112,293	408,401	134,261	191,575	161,494	410,581	336,311	95,259	22,778	11,611	1,962,383
1971	10,708	86,508	123,262	120,518	94,171	146,321	194,344	348,928	418,237	110,670	12,332	9,844	1,683,133
1972	6,181	34,871	76,542	59,357	78,033	181,513	155,728	344,130	219,544	28,377	11,990	10,977	1,206,652
1973	11,383	36,095	86,247	139,557	186,063	173,431	259,406	655,184	400,351	57,348	19,710	5,921	2,030,696
1974	17,349	171,392	136,459	179,857	68,703	228,524	273,856	560,604	441,592	122,525	28,530	9,509	2,238,900
1975	14,696	12,097	35,351	53,853	144,319	224,186	176,275	582,040	596,315	151,335	27,588	14,616	2,032,671
1976	70,107	55,737	31,628	7,883	37,805	70,677	99,529	208,988	39,701	14,412	20,685	14,767	671,919
1977	12,087	8,437	3,219	10,694	16,739	24,385	78,645	105,949	104,440	10,840	3,643	2,862	381,940
1978	1,642	11,780	96,345	189,976	195,780	331,033	354,174	603,286	661,360	309,814	60,841	83,950	2,899,981
1979	9,937	28,398	33,087	153,677	151,480	238,925	260,239	626,236	314,832	66,625	17,080	9,644	1,910,160
1980	29,209	42,379	49,369	528,787	394,146	221,193	304,076	497,417	538,735	346,614	58,826	22,257	3,033,008
1981	7,634	6,617	25,775	48,161	63,489	125,911	243,170	328,483	151,210	21,814	19,142	8,773	1,050,179
1982	29,096	173,742	220,245	227,881	388,399	339,749	660,325	693,110	566,805	322,582	79,983	103,860	3,805,777
1983	152,862	176,231	244,606	261,243	327,834	560,146	303,525	695,933	1,016,194	629,625	205,170	58,030	4,631,399
1984	43,833	310,276	402,190	175,424	150,674	199,589	202,812	535,744	329,550	92,967	21,172	6,534	2,470,765
1985	26,106	85,226	45,811	40,205	69,556	127,513	302,646	341,359	134,995	25,101	15,302	17,837	1,231,657
1986	30,748	49,202	92,981	126,875	637,580	490,232	322,500	539,958	501,005	146,719	30,228	18,821	2,986,849
1987	18,345	7,168	7,714	6,492	43,150	89,948	191,657	206,001	66,198	10,915	5,879	1,732	655,199
1988	10,278	27,191	48,859	70,254	58,572	105,225	158,215	211,686	99,215	23,681	5,324	2,154	820,654
1989	1,849	22,391	26,707	36,978	62,233	286,026	307,446	319,049	208,254	25,970	2,575	13,751	1,313,229
1990	49,972	25,428	20,551	35,542	54,896	133,057	221,034	179,627	101,655	19,799	2,450	1,206	845,217
1991	996	9,297	4,183	4,758	8,904	168,480	179,883	334,909	299,079	66,849	18,875	7,029	1,103,242
1992	15,909	26,027	17,316	25,129	95,340	113,070	231,963	187,646	46,526	56,033	13,075	4,112	832,146
1993	11,154	12,990	45,514	278,917	165,991	319,517	321,485	628,258	505,489	211,712	41,623	13,093	2,555,743
1994	13,209	6,607	17,759	19,494	50,633	103,252	185,944	274,469	115,029	23,351	14,067	7,313	831,127
1995	6,620	62,478	59,639	344,976	147,234	579,813	409,402	658,22					

**Table 4.1.2.2-1
Inflow to Hetch Hetchy Reservoir (Acre-feet)**

Water Year	Oct	Nov	Dec	Jan	Feb	Mar	Apr	May	Jun	Jul	Aug	Sep	WY Total
1921	14,852	16,935	19,452	23,179	28,957	53,234	83,494	201,540	270,010	61,178	7,025	1,817	781,673
1922	1,037	728	4,582	12,895	15,291	26,892	58,915	291,927	392,271	111,925	16,296	3,578	936,337
1923	1,827	4,594	17,778	18,060	15,939	22,723	63,362	241,769	175,305	100,040	13,400	7,860	682,657
1924	15,665	2,174	3,537	5,825	10,346	13,333	58,284	128,382	14,194	9,517	2,156	-809	262,604
1925	3,183	16,022	17,157	13,444	39,753	45,429	106,132	285,650	229,938	78,141	18,355	4,022	857,226
1926	8,463	7,767	13,000	5,901	16,532	41,300	168,649	178,836	59,494	12,524	4,233	1,795	518,494
1927	2,626	17,280	19,335	15,134	38,394	39,015	85,146	234,284	318,714	96,655	13,932	4,318	884,833
1928	5,066	29,462	13,291	14,731	14,971	70,485	77,141	266,757	99,675	17,310	5,258	2,503	616,650
1929	2,299	1,408	4,544	4,362	6,956	28,869	48,361	201,505	132,204	27,394	6,002	2,569	466,473
1930	3,437	1,309	5,758	10,052	18,103	37,301	95,952	138,674	187,152	30,060	5,639	2,458	535,895
1931	4,756	5,508	3,626	6,002	10,264	22,019	74,089	127,418	32,666	7,569	2,176	865	296,958
1932	1,051	1,797	7,807	16,542	32,846	41,647	76,018	231,493	326,652	107,478	13,303	3,634	860,268
1933	2,904	3,300	3,166	5,052	6,855	20,678	62,701	113,109	267,192	43,119	5,885	2,557	536,518
1934	2,765	3,213	6,893	13,359	19,686	49,880	91,043	89,484	61,749	11,185	5,361	3,780	358,398
1935	4,211	17,710	16,907	23,461	31,232	32,356	110,765	234,141	318,149	63,447	12,002	4,338	868,719
1936	3,568	5,024	4,054	17,179	35,823	50,640	136,975	283,146	244,255	81,882	11,998	3,057	877,601
1937	2,949	3,314	6,238	6,986	37,170	34,171	75,221	323,224	239,706	58,483	7,426	2,059	796,947
1938	2,110	4,407	93,614	20,271	30,623	49,130	107,766	299,718	430,110	195,755	32,243	9,505	1,275,252
1939	16,621	16,090	11,780	10,538	13,549	44,307	127,226	124,155	46,657	11,449	6,994	6,581	435,947
1940	20,057	5,915	3,437	39,677	33,610	61,315	101,447	310,891	225,366	34,665	6,470	2,791	845,641
1941	3,221	4,328	28,562	23,873	31,813	43,041	61,743	300,319	329,966	150,875	21,505	4,568	1,003,814
1942	4,342	19,029	53,589	40,512	25,821	35,960	92,025	191,841	363,447	169,206	19,743	4,243	1,019,758
1943	2,870	22,503	24,844	35,766	27,871	58,475	133,978	280,032	228,994	101,286	15,034	5,076	936,729
1944	4,915	5,091	6,781	12,395	16,929	35,499	54,664	214,677	159,701	60,520	8,582	3,925	583,679
1945	3,529	21,771	21,332	15,297	43,783	29,849	94,538	214,921	301,569	115,038	15,142	5,046	881,815
1946	22,217	39,079	43,014	29,397	17,087	41,863	138,684	263,421	165,157	37,481	8,925	4,452	810,777
1947	8,914	18,554	22,770	14,441	20,727	41,246	84,131	242,365	79,202	15,943	4,804	3,082	538,179
1948	17,102	14,090	8,430	14,413	8,567	17,611	62,051	204,468	259,748	55,424	5,988	2,087	669,979
1949	2,176	3,312	5,328	6,339	9,967	20,700	119,136	217,737	153,936	19,136	4,952	2,592	565,311
1950	1,589	5,849	5,440	19,216	26,971	33,698	122,164	243,106	202,040	39,814	4,863	2,877	707,627
1951	4,909	185,303	125,968	33,374	31,331	40,921	114,170	219,386	183,747	43,874	6,994	3,223	993,200
1952	2,322	8,120	23,578	23,332	26,105	38,023	126,111	335,010	318,139	189,368	31,865	7,379	1,129,352
1953	2,987	2,686	10,780	30,397	16,249	28,149	98,914	110,634	248,842	112,477	10,350	3,838	676,303
1954	1,654	2,878	5,278	6,524	23,482	46,812	124,794	240,434	107,883	23,248	4,544	1,869	589,400
1955	1,680	2,930	11,645	12,645	14,368	19,886	50,900	177,620	188,313	27,790	4,919	882	513,578
1956	1,133	3,814	136,376	67,583	26,711	50,554	102,553	264,194	390,375	177,794	28,005	8,315	1,257,407
1957	7,607	10,979	6,676	7,146	29,133	36,202	65,851	168,240	263,393	42,849	6,115	1,642	645,833
1958	3,550	6,892	12,298	11,833	30,333	30,313	84,615	329,998	301,934	138,555	34,114	6,831	991,266
1959	2,289	2,400	2,519	13,979	21,241	35,207	101,746	129,291	90,409	11,159	2,977	20,838	434,055
1960	5,931	2,723	3,271	5,195	20,811	45,519	100,259	166,413	109,680	13,363	4,360	1,448	478,973
1961	2,297	5,018	9,173	5,195	12,920	24,785	81,630	129,146	83,615	11,326	7,379	2,069	374,553
1962	3,178	3,304	7,045	7,690	34,225	29,675	153,711	170,100	282,153	78,292	10,524	2,551	782,448
1963	4,719	2,886	4,814	19,795	68,884	28,080	50,997	322,272	283,414	119,714	16,610	5,437	837,622
1964	4,449	29,635	15,380	11,756	12,125	20,493	62,723	166,986	130,925	23,042	5,332	2,241	485,087
1965	1,095	12,186	152,678	54,303	30,567	35,292	89,798	201,509	271,747	144,631	53,845	9,614	1,057,265
1966	2,987	24,409	17,935	16,151	12,377	42,704	132,016	209,923	52,477	10,742	6,180	3,094	530,995
1967	1,757	14,682	54,046	27,580	25,731	55,924	42,472	246,942	350,743	268,320	44,616	12,194	1,145,007
1968	4,104	4,251	8,963	11,621	34,933	33,880	76,796	164,257	94,907	13,617	5,174	3,360	455,863
1969	9,869	33,915	20,273	69,743	28,451	42,192	123,412	426,825	380,150	198,988	29,640	5,169	1,368,627
1970	10,385	11,837	23,818	70,709	26,576	40,967	52,088	214,551	205,000	53,607	6,230	1,543	717,311
1971	341	17,486	27,925	30,218	25,509	32,991	62,576	165,927	257,223	69,867	9,909	3,481	703,453
1972	2,194	7,955	16,812	14,928	16,465	61,035	56,053	188,521	137,183	15,718	2,239	4,709	523,812
1973	5,399	9,848	24,736	24,218	21,495	24,964	80,634	327,362	239,477	34,204	9,445	95	801,877
1974	2,424	55,910	34,705	41,950	17,691	45,580	71,101	283,357	274,778	72,419	15,695	440	916,050
1975	583	688	9,043	12,785	20,196	34,844	35,010	239,478	328,058	89,885	8,307	3,114	781,991
1976	23,762	20,019	8,894	5,399	10,276	21,602	37,154	121,991	25,392	7,416	5,746	5,185	292,836
1977	5,288	2,440	1,315	1,743	3,683	8,305	40,064	52,768	76,764	10,181	2,257	1,583	206,391
1978	783	3,275	24,609	35,653	34,189	66,018	79,482	246,492	378,644	216,061	38,083	35,361	1,158,650
1979	4,336	5,131	9,780	30,085	21,665	45,483	75,033	303,299	187,442	36,311	5,246	375	724,186
1980	9,209	13,626	13,700	107,381	54,960	40,941	104,152	219,691	315,953	232,032	32,943	4,504	1,149,092
1981	1,154	1,753	5,056	4,588	18,811	27,326	98,630	183,890	100,737	9,477	2,100	863	454,385
1982	7,956	47,328	55,652	36,462	73,410	41,306	136,834	311,236	334,205	191,546	52,620	51,162	1,339,717
1983	55,380	50,053	47,982	34,850	36,060	58,570	45,287	263,161	543,562	385,789	144,621	32,396	1,697,711
1984	18,615	69,094	65,341	33,901	28,011	50,793	87,166	329,749	210,990	68,297	13,107	4,296	979,360
1985	7,718	24,006	13,115	12,835	15,183	28,036	122,325	198,841	92,807	12,827	2,991	5,601	536,285
1986	13,853	12,079	26,140	33,354	86,703	100,867	131,716	311,165	343,860	95,790	17,704	3,915	1,177,146
1987	7,361	2,364	883	3,051	9,447	19,593	88,955	131,331	45,402	5,903	988	-79	315,199
1988	2,456	12,000	13,755	20,733	18,079	36,916	75,665	128,497	67,468	11,679	2,727	1,492	391,467
1989	206	1,827	5,294	11,411	18,781	76,844	141,707	204,379	142,963	24,188	3,804	3,933	635,337
1990	10,979	9,600	9,207	10,477	13,533	40,633	100,504	102,996	66,175	16,302	3,295	1,006	384,707
1991	315	1,706	1,031	-139	2,158	35,205	53,950	151,374	184,304	33,721	3,832	1,287	468,744
1992	3,144	10,731	6,712	7,815	19,299	28,223	101,113	118,177	30,595	24,760	3,782	1,158	355,509
1993	2,660	4,812	9,509	37,287	26,108	71,544	95,135	299,573	284,156	127,180	19,898	3,120	980,982
1994	3,485	1,793	4,901	-5,605	8,741	34,195	81,661	152,920	76,171	5,246	-2,099	-85	361,324
1995	7,053	24,575	20,719	55,252	41,397	89,730	98,023	217,664	414,470	377,198	94,955	17,661	1,458,697
1996	2,646	1,886	17,151	23,706	74,208	61,771	120,313	275,730	249,195	88,608	13,414	3,340	931,968
1997	3,241	37,019	57,181	221,464	33,620	69,408	122,053	313,971	226,964	60,103	14,723	3,846	1,163,593
1998	2,003	2,934	9,330	32,943	38,045	62,993	74,914	146,517	392,983				

4.1.2.3 Inflow to Lake Lloyd and Lake Eleanor

The watershed upstream of Lake Lloyd and Lake Eleanor are also largely unregulated. Prior to the operation of the Eleanor-Cherry Diversion Tunnel and Pumping Plant, inflow values were determined by measurement. These measurements no longer occur, and flows between Lake Eleanor and Lake Lloyd are measured, but the gage does not always provide reliable results. Therefore, inflow to each separate reservoir cannot be determined from current reservoir operation records. The inflow for each reservoir for the period October, 1920 through February, 1960 was determined by measurement. For the remaining period, the inflow for each reservoir is calculated by a relationship representing the historical division of total inflow among the two watersheds. The average annual inflow to Lake Lloyd and Lake Eleanor is 279,300 acre-feet and 169,600 acre-feet, respectively. Table 4.1.2.3-1 and Table 4.1.2.3-2 depict the assumed inflow to Lake Lloyd and Lake Eleanor, respectively

4.1.2.4 Unregulated Flow Below Hetch Hetchy Reservoirs

Over one-third of the calculated total unimpaired flow of the Tuolumne River originates from the watersheds downstream of San Francisco's reservoirs. These flows are unregulated and contribute to the inflow to Don Pedro Reservoir. Table 4.1.2.4-1 depicts the monthly record for these flows. The average annual runoff of this portion of Tuolumne River flow is 651,600 acre-feet

4.1.2.5 Inflow to Calaveras Reservoir

Calaveras Reservoir captures runoff from Calaveras and Arroyo Hondo creeks, and receives runoff from Alameda Creek through the Upper Alameda Diversion Tunnel. Table 4.1.2.5-1 depicts the monthly inflow to Calaveras Reservoir from its watershed. The average annual inflow to Calaveras Reservoir from Calaveras and Arroyo Hondo creeks and its watershed has been estimated to be 38,000 acre-feet. Inflow has varied from essentially no runoff (1924) to almost 151,000 acre-feet (1983) in a year

4.1.2.6 Runoff at Alameda Creek Diversion Dam

Calaveras Reservoir's inflow is supplemented by diversions from Alameda Creek through the Alameda Creek Diversion Tunnel. The typical operation of the diversion is to divert flow of Alameda Creek when it is available up to the capacity of the tunnel. Runoff at the diversion site that exceeds the diversion capacity will flow over the dam and contribute to flows in the creek downstream of the dam. Runoff at the Alameda Creek Diversion Dam is depicted in Table 4.1.2.6-1, and has ranged from essentially no flow to about 50,200 acre-feet in a year. The average annual runoff at the dam is 12,900 acre-feet.

4.1.2.7 Unregulated Runoff below Alameda Creek Diversion Dam

As will be described later, HH/LSM can simulate the supplemental releases from Calaveras Reservoir necessary to comply with a flow requirement below the confluence of the Alameda Creek and Calaveras Creek. The flow requirement is assumed to be partially met by releases from Alameda Creek Diversion Dam to Alameda Creek and the unregulated flows that occur between the diversion dam and the confluence. Table 4.1.2.7-1 depicts the estimation of these unregulated flows.

4.1.2.8 Inflow to San Antonio Reservoir

Located on San Antonio Creek, San Antonio Reservoir receives local runoff averaging 7,600 acre-feet per year. Table 4.1.2.8-1 depicts the estimated inflow to San Antonio Reservoir. The average annual inflow has ranged from essentially none (1924) to about 30,200 acre-feet (1983). San Antonio Reservoir can also receive inflow from Hetch Hetchy, transfers from Calaveras Reservoir, and imported water from the South Bay Aqueduct (State Water Project) through turnouts.

**Table 4.1.2.3-1
Inflow to Lake Lloyd (Acre-feet)**

Water Year	Oct	Nov	Dec	Jan	Feb	Mar	Apr	May	Jun	Jul	Aug	Sep	WY Total
1921	10,784	11,653	10,086	10,340	11,831	25,000	40,451	75,608	89,568	14,440	718	145	300,624
1922	69	52	3,590	7,150	5,068	10,939	28,865	111,788	143,187	37,745	2,382	173	351,008
1923	680	5,187	12,833	8,083	7,539	17,986	35,359	91,658	60,801	25,823	1,664	3,457	271,070
1924	5,679	2,426	1,626	3,961	8,535	6,567	28,370	38,249	2,130	123	26	14	97,706
1925	6,339	11,147	10,072	6,298	19,642	22,007	47,232	95,564	61,660	13,779	4,001	716	298,457
1926	4,735	4,459	7,769	3,172	7,958	24,264	66,567	52,604	11,086	1,095	69	24	183,802
1927	196	10,770	9,987	7,924	18,752	18,353	42,091	79,519	94,195	22,145	1,728	218	305,878
1928	5,716	20,531	4,905	7,275	7,111	43,690	35,082	75,654	21,112	1,799	107	38	223,020
1929	42	1,662	2,503	2,225	4,114	18,228	23,575	69,334	39,025	3,828	216	52	164,804
1930	58	52	7,692	5,383	11,879	19,660	44,894	52,320	51,076	5,516	339	407	199,276
1931	1,353	3,961	1,690	3,848	6,186	13,896	35,256	38,957	7,355	432	28	12	112,974
1932	174	1,432	4,645	7,063	15,386	22,302	37,825	89,889	102,383	27,001	1,418	232	309,750
1933	224	256	1,146	1,956	3,165	10,959	33,840	46,124	72,949	6,623	327	186	177,755
1934	1,601	1,246	8,763	8,906	10,449	30,902	41,599	29,540	14,908	889	139	454	149,396
1935	2,670	11,385	9,179	9,957	13,025	13,581	49,002	86,969	100,756	19,983	897	397	317,801
1936	2,337	3,201	2,358	10,673	16,296	24,910	58,683	97,293	74,210	14,329	692	530	305,512
1937	748	649	6,290	3,366	23,222	13,402	35,722	110,186	68,884	7,402	464	305	270,640
1938	789	3,304	59,615	11,262	12,045	23,314	49,079	112,020	129,521	48,385	3,269	930	453,533
1939	7,214	8,287	5,752	5,072	6,357	22,794	54,101	39,108	8,287	664	230	2,582	160,448
1940	11,431	2,223	4,770	26,959	16,756	36,432	47,038	115,448	68,057	5,345	468	236	335,163
1941	805	2,251	13,436	10,223	15,388	22,213	31,216	121,864	99,747	34,871	1,509	278	353,801
1942	1,020	8,422	30,904	17,639	9,759	15,027	41,155	73,142	113,613	42,331	1,862	242	355,116
1943	399	19,710	14,467	21,299	14,888	29,405	65,568	87,812	59,494	15,842	855	139	329,878
1944	1,428	2,420	3,243	6,212	7,025	16,713	26,551	91,051	51,854	10,364	413	179	217,453
1945	2,176	17,068	15,013	8,557	27,923	12,232	44,118	84,173	89,177	24,123	1,079	419	326,058
1946	18,934	20,951	21,094	12,171	7,805	18,587	54,651	93,340	48,746	5,264	347	442	302,332
1947	3,134	10,534	11,375	5,266	10,437	20,077	35,643	65,377	17,343	1,075	109	60	180,430
1948	10,984	6,270	2,594	8,836	4,637	7,555	29,234	73,799	79,617	10,284	367	305	234,482
1949	847	1,882	2,743	2,771	4,873	7,150	62,218	84,621	43,900	2,475	494	383	214,357
1950	240	3,261	2,102	11,472	12,847	16,454	52,675	89,591	67,240	9,348	764	452	266,446
1951	8,936	82,634	50,632	13,736	12,270	19,325	48,841	67,859	42,658	4,421	547	456	352,315
1952	1,494	7,119	12,252	9,360	10,699	14,233	57,249	129,659	110,489	59,536	4,822	1,537	418,449
1953	633	1,855	5,823	20,443	9,465	16,292	48,172	45,199	76,330	29,000	1,148	498	254,858
1954	660	3,295	4,163	4,623	12,851	29,562	55,874	82,610	37,174	3,925	432	196	235,365
1955	178	3,511	9,398	6,438	8,993	13,357	24,964	71,072	54,129	4,318	365	212	196,935
1956	327	3,199	97,952	27,931	12,430	20,670	42,260	92,999	106,024	37,865	5,950	105	447,712
1957	3,052	6,682	5,563	5,520	20,789	19,107	34,534	72,040	76,969	8,013	-9,771	488	242,986
1958	2,103	4,834	9,600	7,301	16,306	15,047	40,076	123,616	111,156	38,850	6,502	-345	375,046
1959	-2,933	1,277	1,008	14,868	13,702	21,412	46,465	48,901	29,798	1,265	2	10,290	186,055
1960	242	1,093	1,337	3,614	13,047	26,069	43,363	53,625	24,630	473	192	521	168,206
1961	167	3,195	5,802	2,829	8,472	11,482	30,827	38,339	19,046	1,330	564	56	122,109
1962	524	1,206	5,568	5,052	18,808	12,287	68,421	70,182	83,550	15,324	-226	-628	280,068
1963	3,730	-1,375	4,094	11,270	48,132	10,345	25,109	90,072	69,631	17,722	-1,436	-1,504	275,790
1964	3,106	26,252	8,389	5,962	6,859	11,390	30,426	59,848	44,901	4,728	186	176	202,223
1965	508	10,050	77,857	20,874	12,005	15,157	38,824	77,670	91,046	38,855	9,344	2,174	394,364
1966	537	21,368	8,497	5,848	5,048	22,669	48,595	58,822	13,232	952	954	508	187,030
1967	-1,650	17,052	33,759	11,110	11,540	32,724	14,700	101,386	136,643	79,183	7,358	-76	443,729
1968	-945	972	5,550	6,449	21,124	16,131	33,941	51,841	21,537	758	-270	-1,712	155,376
1969	1,130	19,583	10,517	44,888	11,109	17,159	54,976	159,465	122,368	50,614	1,676	238	493,723
1970	8,237	5,204	25,820	47,970	11,489	18,724	23,266	71,384	56,718	7,932	-862	-390	275,492
1971	-365	17,228	14,655	15,338	12,236	19,337	29,812	62,715	76,642	16,518	-631	-575	262,910
1972	-1,977	7,770	9,406	5,101	8,242	29,747	26,912	62,994	40,813	842	-1,095	-282	188,473
1973	1,193	4,976	15,024	12,018	11,268	39,796	118,684	66,835	3,683	-724	-1,939	-279,831	279,831
1974	1,974	43,305	16,256	20,983	7,506	24,914	35,386	100,595	78,147	18,669	521	-1,864	346,392
1975	-1,505	466	4,754	6,986	9,301	17,064	19,243	110,163	108,405	26,220	1,425	694	303,216
1976	19,634	9,518	4,292	1,801	5,876	11,683	19,565	37,983	4,622	422	3,263	1,804	120,463
1977	2,347	881	-52	1,669	3,759	5,413	16,850	24,619	14,773	183	-466	-55	69,921
1978	-774	2,756	20,944	17,502	13,635	33,130	40,077	108,249	120,590	46,297	4,349	13,264	420,019
1979	124	2,577	5,194	16,780	10,192	21,404	41,763	110,515	55,998	7,897	2,304	1,812	276,560
1980	8,107	11,209	11,108	73,558	30,749	19,020	49,008	88,499	105,509	61,521	5,779	1,935	466,002
1981	-3,134	815	3,833	4,136	11,836	14,172	48,284	58,569	22,616	3,025	2,887	1,582	168,621
1982	7,322	43,215	36,750	13,596	41,954	28,146	75,423	106,393	93,115	45,426	4,446	14,999	510,785
1983	40,037	21,615	20,819	14,469	17,159	30,284	25,507	114,749	200,209	120,908	25,772	5,935	637,463
1984	6,204	58,217	46,017	16,377	11,170	24,569	33,201	90,475	55,317	10,427	783	787	353,544
1985	6,480	17,199	7,448	6,298	8,220	14,399	53,270	59,362	19,701	2,094	1,003	1,472	196,946
1986	7,747	8,810	19,240	22,677	64,155	55,145	49,560	92,006	86,338	19,921	2,117	2,481	430,197
1987	2,803	969	1,289	2,474	7,859	13,024	41,189	33,773	7,300	513	492	351	112,036
1988	2,563	5,123	8,777	2,600	4,919	17,408	29,142	36,357	15,023	2,469	61	-206	124,236
1989	749	5,731	5,476	6,398	10,361	50,015	53,802	55,782	36,501	4,540	1,267	4,392	235,014
1990	19,209	7,665	4,295	6,815	6,951	21,960	42,059	34,604	17,128	2,820	1,181	1,285	165,972
1991	1,516	531	-109	837	1,826	26,089	35,151	66,134	53,018	8,333	855	167	194,348
1992	1,777	6,901	2,851	3,717	12,175	17,832	43,224	28,557	5,050	12,099	1,072	57	135,312
1993	2,955	3,910	6,841	24,155	11,887	38,418	53,290	118,990	95,486	35,585	2,979	532	395,028
1994	2,369	831	3,854	3,360	6,621	19,500	36,962	50,397	14,826	1,056	18	25	139,819
1995	3,059	15,895	8,006	29,890	17,554	47,532	54,494	101,754	145,328	116,674	18,035	1,089	559,310
1996	1,316	655	17,996	13,625	44,280	29,733	52,811	113,298	63,109	16,260	2,059	903	356,045
1997	1,917	23,880	49,029	109,513	14,237	34,373	54,645	92,360	56,272	9,415	1,083	1,717	448,441
1998	2,020	3,345	7,049	13,563	18,499	34,160	41,874	78,128	173,556	103,217	7,800	3,582	486,793
1999	2,537	13,179	12,802	15,654	19,541	19,343	36,711	108,924	77,580	12,668	594	32	319,565
2000	-345	3,471	1,244	20,226	19,776	24,814	56,888	102,977	54,412	5,781	1,230	1,368	291,842
2001	3,080	4,221	4,999	5,181	8,985	32,771	41,168	73,276	7,989	2,903	1,787	949	187,309
2002	668	10,999	19,065	15,532	11,670	20,944	53,300	71,488	36,017	1,461	1,122		

**Table 4.1.2.3-2
Inflow to Lake Eleanor (Acre-feet)**

Water Year	Oct	Nov	Dec	Jan	Feb	Mar	Apr	May	Jun	Jul	Aug	Sep	WY Total
1921	6,141	9,158	9,483	11,381	11,572	23,903	30,831	41,387	30,524	5,298	1,228	837	181,743
1922	0	0	1,890	8,422	6,617	10,965	28,191	78,450	59,203	12,349	1,031	1,065	208,183
1923	712	3,249	11,829	7,533	6,480	16,110	33,261	55,672	26,836	10,865	1,734	2,618	176,899
1924	3,215	2,878	2,287	3,418	7,500	5,355	17,389	15,239	444	153	200	95	58,173
1925	2,555	8,301	7,904	5,443	23,619	20,638	37,452	47,197	25,650	6,089	1,976	829	187,653
1926	2,438	2,337	5,211	3,128	7,726	19,704	42,347	22,381	4,834	1,162	672	343	112,283
1927	157	13,825	7,950	6,591	20,834	19,337	34,348	40,227	37,107	9,023	1,581	1,242	192,222
1928	3,178	14,269	4,270	6,496	8,138	44,067	26,876	33,092	7,281	2,132	165	-71	149,893
1929	1,345	974	2,918	3,140	5,288	16,122	19,908	32,622	18,589	2,340	807	129	104,182
1930	-129	355	5,094	5,506	10,199	16,945	30,778	25,932	17,131	2,428	1,505	833	116,577
1931	563	3,267	1,825	3,804	6,569	11,177	19,620	16,756	5,460	1,319	268	139	70,767
1932	107	418	5,167	6,908	17,419	23,203	32,479	54,466	39,931	9,479	1,347	1,269	192,193
1933	103	99	321	1,861	2,823	10,318	25,075	29,576	28,199	3,432	1,452	1,275	104,534
1934	67	377	6,948	6,660	8,759	21,132	16,701	11,003	7,393	845	984	70	80,939
1935	789	7,218	7,222	8,388	11,451	12,901	44,840	60,280	42,531	6,791	490	339	203,240
1936	998	2,368	2,235	11,219	18,323	24,383	47,782	54,528	31,448	6,567	599	311	200,761
1937	313	163	4,766	3,451	17,576	15,124	33,919	17,056	26,785	4,183	627	766	178,729
1938	341	2,116	45,199	7,561	10,481	20,795	38,767	72,616	52,693	14,346	1,111	16	266,042
1939	2,963	4,149	3,001	3,638	4,784	16,994	31,031	15,979	3,174	182	-466	498	85,927
1940	5,044	758	1,941	24,825	17,272	34,691	34,207	48,972	20,328	2,327	-127	-48	190,190
1941	-276	895	14,626	9,586	15,106	19,317	24,756	70,177	34,713	11,651	706	145	201,402
1942	210	3,780	22,358	14,418	9,338	13,581	35,970	52,161	47,415	15,288	954	155	215,628
1943	298	17,401	14,038	20,616	12,498	29,357	43,269	38,192	21,195	6,571	462	351	204,248
1944	533	985	1,495	5,306	5,908	14,154	20,486	46,744	18,543	4,294	200	153	118,801
1945	774	12,599	11,201	5,643	27,332	10,852	31,622	46,149	33,210	8,436	627	492	188,937
1946	8,175	12,953	18,400	9,244	6,264	17,460	36,151	43,861	15,675	2,501	693	315	171,692
1947	605	9,064	9,594	3,713	8,926	16,858	20,979	24,280	7,260	1,331	-109	98	102,599
1948	5,913	3,488	1,390	6,870	3,231	7,001	24,702	46,677	32,587	4,598	641	468	137,566
1949	91	184	1,628	2,487	3,166	8,110	41,266	42,212	14,684	1,690	682	197	116,397
1950	-60	889	1,300	9,673	11,381	15,239	38,364	45,490	23,159	3,751	602	197	149,985
1951	4,246	67,103	47,080	10,606	10,982	15,372	26,690	27,063	11,433	1,771	-12	-36	222,298
1952	-375	4,278	10,081	8,473	9,479	14,640	46,943	82,542	46,306	17,548	2,116	672	242,703
1953	406	686	4,503	15,957	6,365	12,946	36,058	28,306	31,291	9,142	512	335	146,507
1954	361	950	2,656	4,144	10,566	26,696	44,331	40,691	14,107	2,031	308	143	146,984
1955	64	1,277	8,168	5,294	7,648	10,263	18,857	34,808	17,843	1,878	18	-91	106,027
1956	-387	1,121	56,350	27,669	9,880	18,774	30,514	55,474	37,158	11,405	1,033	-365	248,626
1957	1,263	2,771	2,596	3,491	16,974	16,974	24,450	40,984	27,070	4,711	95	56	141,435
1958	381	2,410	8,743	6,083	14,567	12,853	29,169	82,499	51,779	16,348	2,283	682	227,797
1959	359	198	208	11,970	9,673	16,975	26,136	18,500	10,046	625	54	6,196	100,940
1960	375	391	141	2,051	12,256	23,776	32,579	29,773	9,722	179	139	422	111,804
1961	77	2,202	4,413	2,488	7,851	10,473	23,161	21,286	7,517	505	410	45	80,428
1962	242	831	4,234	4,445	17,430	11,207	51,406	38,966	32,977	5,812	-165	-509	166,876
1963	1,723	-947	3,114	9,915	44,607	9,436	18,865	50,009	27,484	6,722	-1,045	-1,221	168,662
1964	1,435	18,092	6,380	5,245	6,357	10,389	22,860	33,228	17,723	1,794	135	143	123,781
1965	234	6,927	59,215	18,363	11,126	13,823	29,169	43,123	35,936	14,738	6,794	1,765	241,213
1966	248	14,727	6,463	5,144	4,679	20,676	36,510	32,658	5,222	361	694	412	127,794
1967	-762	11,752	25,676	9,774	10,695	29,845	11,045	56,290	53,933	30,035	5,350	-61	243,572
1968	-437	670	4,221	5,674	19,577	14,712	25,500	28,783	8,501	287	-196	-1,390	105,902
1969	522	13,497	7,999	39,487	10,295	15,650	41,304	88,536	48,298	19,199	1,218	193	286,198
1970	3,805	3,587	19,637	42,199	10,647	17,077	17,480	39,633	22,386	3,008	-626	-316	178,517
1971	-169	11,873	11,146	13,492	11,341	17,637	22,399	34,820	30,251	6,266	-458	-466	158,132
1972	-913	5,355	7,154	4,487	7,639	27,131	20,219	34,975	16,109	320	-797	-228	121,451
1973	551	3,430	11,427	10,572	8,357	10,277	29,899	65,894	26,380	1,397	-527	-1,574	166,083
1974	912	29,845	12,364	18,458	6,957	22,723	26,586	55,851	30,845	7,082	379	-1,512	210,490
1975	-695	321	3,616	6,145	8,620	15,564	14,458	61,163	42,787	9,945	1,036	564	163,524
1976	9,071	6,560	3,264	1,585	5,445	10,655	14,700	21,088	1,824	160	2,372	1,465	78,189
1977	1,084	608	-40	1,469	3,483	4,936	12,660	13,668	5,831	69	-338	-44	43,386
1978	-358	1,899	15,929	15,397	12,637	30,216	30,110	60,101	47,597	17,561	3,162	10,765	245,016
1979	57	1,776	3,950	14,761	9,446	19,521	31,377	61,359	22,103	2,996	1,675	1,470	170,491
1980	3,746	7,725	8,449	64,708	28,497	17,347	36,821	49,136	41,645	23,336	4,202	1,570	287,182
1981	-1,448	562	2,915	3,639	10,970	12,926	36,277	32,518	8,927	1,148	2,099	1,284	111,817
1982	3,383	29,783	27,951	11,961	38,882	25,670	56,666	59,070	36,753	17,230	3,232	12,173	322,754
1983	18,497	14,897	15,834	12,728	15,903	27,621	19,163	63,710	79,022	45,862	18,739	4,817	336,793
1984	2,866	40,122	34,998	14,406	10,353	22,408	24,944	50,232	21,834	3,955	570	639	227,327
1985	2,993	11,853	5,664	5,541	7,618	13,132	40,023	32,959	7,776	794	729	1,194	130,276
1986	3,579	6,072	14,634	19,948	59,457	50,294	37,235	51,082	34,078	7,556	1,539	2,014	287,488
1987	1,295	667	980	2,177	7,283	11,878	30,946	18,751	2,881	195	357	284	77,694
1988	1,184	3,531	6,676	2,287	4,558	15,877	21,895	20,186	5,930	937	44	-167	82,938
1989	346	3,950	4,164	5,628	9,603	45,616	40,423	30,971	14,407	1,722	921	3,564	161,315
1990	8,875	5,283	3,266	5,996	6,443	20,028	31,599	19,212	6,761	1,070	858	1,042	110,433
1991	700	366	-83	736	1,693	23,795	26,410	36,719	20,926	3,161	621	136	115,180
1992	821	4,756	2,169	3,297	11,238	16,460	32,608	15,377	1,964	4,705	842	52	94,289
1993	1,327	2,832	5,161	21,420	10,972	35,462	40,202	64,071	37,133	13,839	2,341	491	235,251
1994	1,064	601	2,908	2,979	6,112	18,000	27,884	27,137	5,765	410	14	23	92,897
1995	1,374	11,510	6,039	26,507	16,203	43,875	41,110	54,791	56,516	45,373	14,171	1,006	318,475
1996	591	474	13,576	12,083	40,873	27,446	39,840	61,006	24,542	6,324	1,618	833	229,206
1997	861	17,293	36,986	97,115	13,141	31,729	41,223	49,733	21,884	3,662	851	1,585	316,063
1998	908	2,423	5,318	12,028	17,076	31,533	31,589	42,069	67,494	40,140	6,128	3,306	260,012
1999	1,140	9,544	9,657	13,881	18,038	17,855	27,694	58,651	30,170	4,927	467	30	192,054
2000	-155	2,513	938	17,936	18,255	22,906	42,916	55,449	21,160	2,248	966	1,262	186,394
2001	1,384	3,057	3,772	4,595	8,293	30,250	31,057	39,456	3,107	1,129	1,404	876	128,380
2002	300	7,965	14,383	13,774	10,772	19,332	40,209	38,494	14,006	568	881	507	161,191
Avg (21-02)	1,538	6,591	9,885	11,307	12,493	19,493	30,946	43,125	24,867	7,142	1,364	868	169,617
Max (21-02)	18,497	67,103	59,215	97,115	59,45								

**Table 4.1.2.4-1
Unregulated Flows below Hetch Hetchy Reservoirs (Acre-feet)**

Water Year	Oct	Nov	Dec	Jan	Feb	Mar	Apr	May	Jun	Jul	Aug	Sep	WY Total
1921	9,299	15,550	30,525	151,299	103,584	129,637	99,574	123,650	68,218	14,257	4,527	3,764	753,884
1922	4,690	5,304	44,537	43,255	162,483	132,483	144,375	235,360	157,265	32,540	7,508	5,577	975,377
1923	7,385	18,579	81,491	79,911	49,557	56,286	133,757	132,197	56,185	21,109	10,540	8,331	655,328
1924	3,953	6,146	6,307	12,131	15,242	12,602	34,812	27,525	82	7,017	-4,272	-3,217	118,328
1925	2,583	12,439	15,912	19,070	144,076	77,564	159,513	110,028	35,131	13,849	-1,683	286	588,768
1926	-520	1,646	6,783	6,751	68,368	42,170	104,739	49,963	13,816	4,133	-1,721	-785	295,343
1927	2,503	32,200	22,744	33,554	145,145	83,012	189,914	100,058	26,168	18,468	7,348	7,341	668,455
1928	1,382	22,749	21,642	22,761	51,987	185,176	124,669	72,270	24,584	6,381	1,771	93	535,465
1929	-4,229	1,744	8,150	9,330	24,091	36,185	56,256	74,658	34,868	7,178	-2,457	-12,021	233,753
1930	-1,506	-480	4,482	18,086	29,883	72,686	74,295	57,876	30,868	10,839	2,506	-4,668	294,847
1931	2,351	7,636	3,574	12,433	21,466	19,176	25,063	26,191	3,529	899	-1,532	789	121,575
1932	348	2,395	76,042	48,855	174,547	84,436	98,726	148,306	63,691	31,886	15,900	6,909	752,041
1933	2,487	-458	6,225	18,032	18,633	40,630	49,323	62,007	57,805	21,922	8,402	522	285,530
1934	-4,725	3,122	18,244	35,980	51,086	48,334	37,047	19,009	11,042	-846	-375	262	218,180
1935	3,513	11,309	18,643	64,097	51,560	64,097	260,882	149,308	50,039	19,366	78,046	-1,004	713,098
1936	4,688	8,994	9,508	65,716	281,539	107,592	149,501	85,262	40,303	19,672	4,521	-974	776,322
1937	308	4,484	10,028	17,631	195,935	146,813	150,737	129,435	64,035	21,291	8,337	1,668	750,702
1938	5,914	8,931	114,133	62,844	269,590	331,600	226,768	235,806	99,276	46,705	18,845	9,086	1,429,498
1939	13,450	14,959	16,185	23,346	35,229	60,019	69,543	36,794	16,219	5,049	7,26	7,173	298,692
1940	8,411	7,720	10,100	135,027	182,362	211,698	142,165	95,787	33,750	11,819	3,944	-964	841,820
1941	7,556	7,531	72,431	71,768	156,689	175,509	161,872	170,316	70,011	26,658	6,769	3,198	930,308
1942	1,466	6,328	54,683	92,242	97,515	84,139	167,844	154,847	73,109	26,618	7,601	-1,361	765,031
1943	1,486	26,793	39,498	168,638	108,499	254,684	142,356	88,491	43,207	17,198	8,451	-361	898,940
1944	4,726	7,130	9,414	18,814	50,551	68,858	62,919	103,325	37,082	12,449	2,008	-1,895	375,381
1945	2,643	37,608	33,763	26,104	205,805	111,477	113,986	109,829	38,304	15,459	-86	-7,131	687,761
1946	10,980	25,312	125,230	68,099	38,733	77,892	118,356	87,891	34,976	10,923	-2,038	-1,845	594,509
1947	3,417	25,849	32,976	18,455	40,131	57,876	51,471	38,475	6,940	2,533	-5,405	-356	272,362
1948	4,205	4,301	4,757	9,558	9,427	40,840	104,666	111,301	61,812	17,419	-1,823	-385	366,078
1949	2,033	2,833	8,069	8,302	21,111	87,279	95,627	91,852	27,847	6,168	-1,617	545	350,049
1950	2,146	4,217	4,576	37,097	73,124	62,923	115,926	89,249	26,947	9,327	285	-4,343	421,474
1951	6,348	186,520	285,314	101,528	84,328	93,082	64,108	58,555	18,893	10,035	2,041	-3,371	907,381
1952	5,582	11,333	75,501	177,528	101,475	172,947	236,114	244,119	119,248	25,412	15,288	7,317	1,191,864
1953	4,640	6,634	31,950	78,290	31,452	49,262	86,455	75,380	57,948	19,202	5,783	726	447,722
1954	4,650	10,046	12,099	26,600	54,480	110,133	124,175	83,813	25,977	8,720	-2,202	-1,054	457,437
1955	2,140	7,662	20,780	42,323	30,157	38,889	49,231	82,948	31,892	5,314	-4,378	201	307,159
1956	2,892	4,828	358,946	308,113	107,078	88,527	106,459	146,995	48,259	17,177	5,687	4,110	1,199,071
1957	9,444	3,830	9,367	18,885	56,857	81,252	47,660	98,725	37,549	11,587	12,300	-145	387,311
1958	5,262	4,253	17,391	32,907	115,529	198,553	271,144	225,282	114,346	38,146	11,974	9,465	1,044,252
1959	6,176	1,959	1,499	37,822	71,594	45,428	49,696	34,791	8,580	5,167	-1,537	7,397	268,569
1960	-1,228	5,326	7,552	14,342	73,267	54,134	62,188	53,595	18,319	2,049	1,107	2,750	293,401
1961	2,848	5,241	13,298	8,148	17,311	24,651	29,200	31,037	5,595	12,127	4,161	1,666	155,283
1962	1,052	2,688	6,838	6,682	162,849	85,854	115,488	83,231	46,895	17,458	3,930	3,578	536,543
1963	7,112	8,183	17,427	52,114	147,106	64,336	152,558	161,304	82,909	34,969	17,739	13,322	759,079
1964	8,687	30,962	17,871	30,583	26,463	32,995	53,177	63,012	31,476	11,653	6,698	5,598	319,175
1965	7,017	23,084	227,390	195,156	87,362	76,612	168,242	126,675	77,798	29,387	17,431	9,378	1,045,532
1966	3,664	69,064	55,959	50,607	52,862	60,369	81,423	53,454	15,417	10,269	1,480	5,745	460,277
1967	7,738	23,845	108,114	86,501	67,071	187,818	221,318	244,304	202,213	94,966	20,204	8,202	1,272,294
1968	7,213	5,248	12,886	23,486	58,853	58,068	51,255	42,790	16,062	3,993	5,320	4,300	289,474
1969	1,136	13,855	42,470	423,431	236,142	188,458	269,995	285,440	165,562	47,345	22,271	7,582	1,703,687
1970	16,078	18,686	43,018	247,523	85,549	114,807	68,660	85,013	52,207	30,712	18,036	10,774	791,063
1971	10,901	39,921	69,536	61,470	45,085	76,356	79,557	85,466	54,121	18,019	10,802	7,404	558,638
1972	6,877	13,791	43,170	34,841	45,687	63,600	52,544	57,640	25,439	11,497	11,052	6,778	372,916
1973	4,240	17,841	35,060	92,749	147,194	126,922	109,077	143,244	67,659	18,064	11,516	9,339	782,905
1974	12,039	42,332	73,134	98,466	36,549	135,307	140,783	120,801	57,822	24,355	11,935	12,445	765,968
1975	16,313	10,622	17,938	27,937	106,202	156,714	107,564	171,236	117,065	25,285	16,820	10,244	783,940
1976	17,640	19,640	15,178	-902	16,208	26,737	28,110	27,926	7,863	6,414	9,304	6,313	180,431
1977	3,368	4,508	1,996	5,813	5,814	5,731	9,071	14,894	7,072	407	2,190	1,378	62,242
1978	1,991	3,850	34,863	121,424	135,319	201,669	204,550	188,444	114,529	29,895	15,247	24,560	1,076,296
1979	5,420	18,914	14,163	92,051	110,177	152,517	112,066	151,063	49,289	19,421	7,855	5,987	738,923
1980	8,147	9,819	16,112	283,140	279,940	143,885	114,095	140,091	75,628	29,725	15,902	14,248	1,130,732
1981	11,062	3,487	13,971	35,798	21,872	71,487	59,979	53,506	18,930	8,164	12,056	5,044	315,356
1982	10,435	53,416	99,892	165,862	234,153	244,627	391,402	216,411	102,732	68,380	19,685	25,526	1,632,521
1983	38,948	89,666	159,971	199,196	258,712	443,671	213,568	254,313	193,401	77,066	16,038	14,882	1,959,432
1984	16,148	142,843	255,834	110,740	101,140	101,819	57,501	65,288	41,409	10,288	6,712	812	910,534
1985	8,915	32,168	19,584	15,531	38,535	71,946	87,028	50,197	14,711	9,386	10,579	9,570	368,150
1986	5,569	22,241	32,967	50,896	427,265	283,926	103,989	85,705	36,729	23,452	8,868	10,411	1,092,018
1987	6,886	3,168	4,562	-1,210	18,561	45,453	30,567	22,146	10,615	4,304	4,042	1,176	150,270
1988	4,075	6,537	19,651	44,634	31,016	35,024	31,513	26,646	10,794	8,596	2,492	1,035	222,013
1989	548	10,883	11,773	13,541	23,488	113,551	71,514	27,917	14,383	-4,480	-3,417	1,862	281,563
1990	10,909	2,880	3,783	12,254	27,969	50,436	46,872	22,815	11,591	-393	-2,884	-2,127	184,105
1991	-1,535	6,694	3,344	3,324	3,227	83,391	64,372	80,682	40,831	21,634	13,567	5,439	324,970
1992	10,167	3,639	5,584	10,300	52,628	50,555	55,018	25,535	8,917	14,469	7,379	2,845	247,036
1993	4,212	1,436	24,003	196,055	117,024	174,093	132,858	145,624	88,714	35,108	16,405	8,950	944,482
1994	6,291	3,382	6,096	18,760	29,159	31,557	39,437	44,015	18,267	16,639	16,134	7,350	237,087
1995	-4,866	10,498	24,875	233,327	72,080	398,676	215,775	284,013	175,709	101,194	22,754	7,037	1,541,072
1996	-1,629	184	21,772	74,643	190,825	174,875	120,391	127,790	47,656	15,687	8,008	8,533	788,735
1997	4,634	32,978	252,698	574,286	103,048	93,507	68,847	71,151	9,297	16,178	14,389	28,935	1,269,948
1998	3,180	8,640	14,660	158,069	293,935	219,919	202,610	203,224	215,239	96,195	18,484	2,765	1,43

**Table 4.1.2.5-1
Inflow to Calaveras Reservoir from Watershed (Acre-feet)**

Water Year	Oct	Nov	Dec	Jan	Feb	Mar	Apr	May	Jun	Jul	Aug	Sep	WY Total
1921	40	598	10,091	14,286	7,617	2,099	899	577	172	110	61	46	36,597
1922	64	68	5,739	3,508	29,495	13,743	4,809	1,335	307	166	89	61	59,383
1923	98	629	14,893	7,893	6,687	1,387	4,355	617	295	110	61	46	37,072
1924	25	0	0	0	0	3	12	0	0	0	0	0	40
1925	18	46	1,246	1,175	10,944	755	1,633	1,691	184	61	37	31	17,821
1926	43	46	101	1,215	21,697	1,636	6,095	430	270	95	55	40	31,723
1927	61	4,919	1,614	4,257	20,233	5,521	6,973	841	338	129	74	52	45,012
1928	77	83	3,167	1,614	3,035	19,414	7,436	746	28	107	61	43	35,811
1929	64	71	2,836	2,173	2,200	3,152	1,329	371	172	49	31	25	12,472
1930	37	46	101	2,872	2,872	11,877	967	448	98	68	40	31	19,457
1931	71	74	175	1,215	519	626	209	157	83	40	31	28	3,225
1932	25	46	9,762	5,223	9,418	1,169	826	408	239	83	49	37	27,286
1933	80	83	147	2,774	948	1,366	936	626	129	52	37	31	7,209
1934	34	49	3,247	4,382	4,465	1,464	442	215	163	55	37	28	14,580
1935	49	184	371	10,787	994	3,965	8,955	1,826	307	107	61	46	27,654
1936	68	89	387	2,673	18,033	2,955	2,980	1,102	307	107	61	46	28,808
1937	68	71	276	1,200	13,994	18,791	5,641	1,541	374	144	80	58	42,237
1938	68	129	6,033	6,478	36,996	24,809	6,767	1,869	531	230	123	83	84,115
1939	218	411	1,703	1,200	2,584	2,240	718	307	184	68	46	37	9,716
1940	34	46	101	10,867	26,414	16,210	7,884	1,541	442	184	98	68	63,888
1941	98	157	5,634	12,328	27,491	20,393	25,506	4,576	611	273	141	95	97,302
1942	153	338	6,933	20,203	18,192	7,246	10,870	3,799	479	203	107	74	68,596
1943	129	1,237	1,160	22,022	8,176	9,369	3,210	1,439	402	157	86	61	47,448
1944	107	242	476	902	7,101	5,766	1,550	899	242	83	52	40	17,462
1945	55	344	786	1,909	16,333	4,913	2,010	1,534	316	110	64	46	28,421
1946	64	448	14,746	7,589	3,640	2,207	1,811	1,132	310	110	64	46	32,168
1947	117	783	1,080	1,105	1,961	2,731	1,835	706	230	83	55	46	10,732
1948	61	132	399	384	537	1,949	3,250	1,476	181	68	46	40	8,522
1949	46	64	528	574	1,488	16,523	1,875	1,307	307	101	61	46	22,922
1950	52	58	313	5,812	6,405	1,525	1,221	611	184	61	40	31	16,314
1951	46	7,424	18,217	8,424	7,019	8,415	1,737	1,445	427	172	95	64	53,485
1952	83	218	8,458	34,464	13,577	20,644	5,051	1,605	540	236	126	86	85,088
1953	150	218	9,811	14,381	3,127	4,082	1,584	1,587	325	120	68	49	35,501
1954	86	534	316	3,416	6,132	5,186	2,142	890	264	89	55	40	19,150
1955	58	199	3,597	5,549	1,682	1,798	1,295	893	209	71	46	34	15,430
1956	37	86	35,572	22,787	16,422	6,190	2,240	1,212	528	230	123	83	85,509
1957	190	203	310	967	7,556	2,007	1,329	1,881	221	77	49	37	14,826
1958	40	175	1,077	5,656	27,074	23,882	35,243	3,759	626	279	144	98	98,054
1959	163	172	353	3,597	10,428	1,565	844	494	196	64	40	31	17,947
1960	49	55	138	1,025	5,595	654	503	396	120	46	31	25	8,636
1961	55	325	295	694	534	1,608	365	273	110	46	37	31	4,373
1962	31	52	264	319	14,795	5,960	1,215	939	255	86	49	37	24,002
1963	58	138	939	15,596	22,391	6,322	12,632	5,895	516	215	117	80	64,898
1964	138	1,528	749	5,407	927	1,046	810	537	166	61	40	31	11,441
1965	37	417	16,035	28,835	4,757	1,666	9,682	1,614	448	187	101	71	63,851
1966	120	1,590	3,848	3,275	4,392	1,620	316	356	190	64	40	31	15,842
1967	43	356	4,981	18,275	7,261	14,792	14,660	6,202	485	203	110	74	67,442
1968	132	196	758	7,497	4,014	3,198	1,580	890	230	77	46	37	18,656
1969	46	230	2,437	27,918	31,561	11,054	3,535	1,169	549	196	95	89	78,880
1970	147	196	991	17,330	3,842	10,358	1,267	654	276	101	74	58	35,295
1971	64	1,633	12,512	6,233	1,108	3,106	1,780	804	335	110	52	40	27,777
1972	68	117	3,281	1,145	2,145	470	335	157	95	37	12	18	7,878
1973	46	4,873	2,452	18,140	31,668	15,035	2,836	1,062	430	181	98	92	76,913
1974	270	3,029	13,227	12,797	2,013	12,368	12,509	1,746	669	347	129	55	59,159
1975	166	295	908	1,832	22,219	24,579	6,871	1,722	598	316	193	157	59,856
1976	203	239	270	242	276	678	276	120	52	31	25	31	2,443
1977	89	95	101	457	193	405	206	147	55	25	15	18	1,808
1978	18	46	1,157	21,298	12,214	15,203	6,165	1,455	562	196	101	92	58,509
1979	89	160	236	4,168	11,189	6,012	1,958	694	206	98	52	43	24,904
1980	110	335	2,820	18,825	36,164	7,691	2,891	1,148	470	224	114	68	70,858
1981	80	107	328	9,339	1,817	8,372	1,574	577	199	49	28	25	22,495
1982	40	2,167	4,508	22,526	13,607	10,057	31,527	4,260	583	258	135	92	89,759
1983	126	1,946	9,142	29,102	34,857	53,571	12,368	8,231	875	408	209	138	150,971
1984	285	4,272	18,539	2,912	1,633	1,811	1,593	1,366	341	123	71	52	32,997
1985	98	2,823	1,427	700	2,949	3,523	516	528	227	80	52	40	12,963
1986	37	166	460	436	41,430	23,394	4,014	1,320	485	206	110	46	72,104
1987	71	77	242	427	1,329	1,175	393	129	86	34	25	21	4,008
1988	31	80	881	1,691	384	279	344	157	83	34	25	21	4,008
1989	34	52	377	417	371	1,409	377	110	80	34	25	21	3,308
1990	31	374	298	945	1,117	638	316	236	89	37	25	21	4,128
1991	40	61	212	193	178	8,768	1,185	402	169	61	40	31	11,340
1992	40	52	476	697	15,344	3,818	1,495	509	252	83	49	37	22,851
1993	52	55	1,694	21,559	18,711	8,065	2,342	1,528	402	163	89	61	54,721
1994	110	166	798	620	5,981	1,080	786	691	144	52	37	28	10,493
1995	21	169	494	33,693	4,324	37,975	5,054	2,314	1,142	571	246	166	86,168
1996	160	150	2,019	14,961	27,700	13,202	2,225	1,565	691	252	120	114	63,158
1997	166	4,870	22,648	43,161	4,376	1,774	1,007	555	310	160	101	110	79,239
1998	135	755	2,575	22,265	58,199	11,036	10,170	3,990	1,900	921	442	279	112,665
1999	344	460	1,139	5,318	13,442	4,947	7,384	1,924	921	310	206	89	36,483
2000	117	239	295	3,916	19,242	11,260	1,605	826	384	206	89	123	38,300
2001	147	206	347	1,507	8,663	7,203	1,709	537	184	77	46	37	20,663
2002	46	199	5,398	3,443	1,841	4,367	1,142	531	215	55	28	21	17,287
Avg (21-02)	87	684	3,835	8,402	10,979	7,819	4,219	1,319	339	141	77	56	37,957
Max (21-02)	344	7,424	35,572	43,161	58,199	53,571	35,243	8,231	1,900	921	442	279	150,971
Min (21-02)	18	0	0	0	0	3	12	0	0	0	0	0	40

**Table 4.1.2.6-1
Runoff at Alameda Creek Diversion Dam (Acre-feet)**

Water Year	Oct	Nov	Dec	Jan	Feb	Mar	Apr	May	Jun	Jul	Aug	Sep	WY Total
1921	3	199	3,370	4,772	2,544	700	301	193	58	9	6	3	12,159
1922	6	6	1,918	1,172	9,857	4,591	1,608	445	104	12	6	3	19,730
1923	6	212	5,012	2,655	2,250	466	1,464	209	21	9	6	3	12,312
1924	0	0	0	0	0	3	9	0	0	0	0	0	12
1925	0	3	420	396	3,695	255	552	571	15	6	3	3	5,920
1926	3	3	9	411	7,325	552	2,056	144	21	6	3	3	10,539
1927	3	1,504	494	1,301	6,184	1,688	2,130	258	25	9	6	3	13,604
1928	6	6	1,062	540	1,016	6,500	2,489	249	9	9	6	3	11,895
1929	6	6	957	733	743	1,062	448	126	58	3	3	3	4,149
1930	3	3	34	964	3,980	325	150	34	6	3	3	3	6,469
1931	6	6	61	430	184	221	74	55	31	3	3	3	1,077
1932	3	3	3,265	1,746	3,149	390	276	135	80	6	3	3	9,059
1933	6	6	49	951	325	470	319	215	43	3	3	3	2,394
1934	3	3	1,089	1,470	1,498	491	147	71	55	3	3	3	4,837
1935	3	15	126	3,627	335	1,335	3,014	614	104	9	6	3	9,191
1936	6	6	129	896	6,052	991	1,000	368	104	9	6	3	9,572
1937	6	6	92	402	4,686	6,291	1,887	516	126	12	6	3	14,034
1938	6	9	2,016	2,164	12,362	8,289	2,262	626	178	18	9	6	27,945
1939	18	34	605	424	915	795	255	107	64	6	3	3	3,228
1940	3	3	34	3,627	8,820	5,414	2,633	516	147	15	6	6	21,224
1941	6	12	1,884	4,118	9,188	6,816	8,525	1,528	206	21	12	6	32,325
1942	12	25	2,326	6,779	6,104	2,431	3,646	1,274	160	15	9	6	22,787
1943	9	95	396	7,519	2,793	3,201	1,096	491	138	12	6	6	15,762
1944	9	18	163	307	2,415	1,961	528	307	83	6	3	3	5,803
1945	3	28	264	644	5,518	1,660	678	519	107	9	6	3	9,440
1946	6	34	4,987	2,566	1,231	746	611	384	104	9	6	3	10,686
1947	9	64	390	399	706	985	660	255	83	6	6	3	3,566
1948	6	9	138	132	184	669	1,114	506	61	6	3	3	2,833
1949	3	6	178	193	500	5,549	629	439	101	9	6	3	7,617
1950	3	3	104	1,955	2,154	513	411	206	61	6	3	3	5,423
1951	3	632	6,819	3,155	2,627	3,149	651	540	160	15	9	6	17,766
1952	6	15	2,830	11,527	4,542	6,905	1,691	537	181	18	9	6	28,268
1953	12	15	3,302	4,840	1,053	1,375	534	534	110	9	6	3	11,794
1954	6	43	107	1,172	2,105	1,780	307	737	92	6	3	3	6,362
1955	3	15	1,218	1,881	571	611	439	304	71	6	3	3	5,125
1956	3	6	11,877	7,608	5,484	2,065	749	405	175	18	9	6	28,406
1957	15	15	104	331	2,584	687	454	644	77	6	3	3	4,926
1958	3	12	359	1,890	9,047	7,979	11,775	1,255	209	21	12	6	32,570
1959	12	12	120	1,218	3,535	531	285	169	68	6	3	3	5,963
1960	3	3	46	347	1,894	221	172	135	40	3	3	3	2,869
1961	3	28	107	252	193	586	132	98	40	3	3	3	1,449
1962	3	3	89	107	4,956	1,998	408	316	86	6	3	3	7,979
1963	150	9	313	5,183	7,442	2,102	4,198	1,958	172	15	9	6	21,559
1964	12	132	282	2,044	350	396	307	203	64	6	3	3	3,802
1965	3	31	5,380	9,673	1,596	559	3,250	540	150	15	6	6	21,209
1966	9	132	1,406	1,194	1,602	592	114	129	71	6	3	3	5,260
1967	3	28	1,669	6,126	2,434	4,959	4,916	2,078	163	15	9	6	22,406
1968	9	15	258	2,541	1,360	1,083	537	301	80	6	3	3	6,196
1969	3	18	813	9,333	10,551	3,695	1,182	390	184	15	6	6	26,196
1970	12	15	335	5,831	1,292	3,483	427	221	92	9	6	3	11,726
1971	6	129	4,389	2,185	390	1,089	623	282	117	9	3	3	9,225
1972	6	9	1,117	390	730	160	114	52	34	3	0	0	2,615
1973	3	390	859	6,365	11,109	5,275	994	371	150	15	9	6	25,549
1974	21	242	4,625	4,474	703	4,324	4,373	611	233	28	9	3	19,647
1975	12	21	307	617	7,491	8,286	2,317	580	203	25	15	12	19,886
1976	18	21	107	98	110	270	110	49	21	3	3	3	816
1977	6	9	37	169	71	150	77	55	21	3	0	0	598
1978	0	3	387	7,117	4,082	5,082	2,059	488	187	15	6	6	19,432
1979	6	12	80	1,402	3,769	2,025	660	233	71	6	3	3	8,271
1980	9	25	945	6,313	12,125	2,578	970	384	157	18	9	6	23,538
1981	6	9	110	3,133	611	2,808	528	193	68	3	3	3	7,476
1982	3	169	1,534	7,660	4,628	3,419	10,720	1,449	199	18	9	6	29,814
1983	9	150	3,081	9,811	11,751	18,057	4,168	2,774	295	31	15	9	50,152
1984	25	365	6,939	1,089	611	678	595	513	129	9	6	3	10,962
1985	9	261	580	285	1,200	1,436	209	215	6	6	3	3	4,303
1986	3	12	153	147	13,847	7,820	1,341	442	163	15	9	3	23,956
1987	6	6	86	147	463	408	138	46	31	3	3	3	1,341
1988	3	6	304	583	132	95	120	55	28	3	3	3	1,335
1989	3	3	132	144	129	485	129	37	28	3	3	3	1,099
1990	3	31	107	347	408	233	117	86	34	3	3	3	1,375
1991	3	6	71	64	61	2,961	399	135	58	6	3	3	3,772
1992	3	3	160	233	5,143	1,280	500	172	86	6	3	3	7,592
1993	3	3	568	7,206	6,251	2,694	783	513	135	12	6	6	18,180
1994	9	12	273	212	2,044	368	267	236	49	3	3	3	3,480
1995	0	52	417	14,528	927	12,954	1,182	1,679	583	166	34	21	32,543
1996	6	9	841	9,679	14,372	7,807	1,117	491	163	74	31	12	34,602
1997	28	1,350	7,681	14,593	1,476	660	331	169	77	34	18	9	26,426
1998	12	227	1,111	9,151	16,968	3,127	3,284	1,197	559	230	110	74	36,050
1999	52	89	288	3,618	6,307	2,216	3,170	589	236	77	40	28	16,710
2000	18	37	46	2,520	7,513	4,192	562	279	107	37	12	6	15,329
2001	9	15	37	390	3,182	1,915	473	166	37	9	6	3	6,242
2002	3	31	2,461	1,224	694	1,356	353	184	77	15	6	0	6,405
Avg (21-02)	9	88	1,327	2,993	3,759	2,683	1,425	454	111	17	8	5	12,880
Max (21-02)	150	1,504	11,877	14,593	16,968	18,057	11,775	2,774	583	230	110	74	50,152
Min (21-02)	0	0	0	0	0	3	9	0	0	0	0	0	12

**Table 4.1.2.7-1
Unregulated Runoff below Alameda Creek Diversion Dam (Acre-feet)**

Water Year	Oct	Nov	Dec	Jan	Feb	Mar	Apr	May	Jun	Jul	Aug	Sep	WY Total
1921	0	0	383	955	517	181	101	80	22	0	0	0	2,239
1922	0	0	299	246	1,767	705	221	46	10	1	0	0	3,295
1923	0	19	576	432	287	70	112	16	1	0	0	0	1,513
1924	0	0	0	0	0	0	1	0	0	0	0	0	1
1925	0	0	36	30	584	78	116	33	6	0	0	0	883
1926	0	0	0	2	876	57	260	6	0	0	0	0	1,200
1927	0	75	82	198	838	273	278	89	37	0	0	0	1,872
1928	0	0	94	133	197	830	360	21	7	3	0	0	1,645
1929	0	5	39	37	68	117	15	3	1	0	0	0	284
1930	0	0	17	172	108	642	57	37	24	0	0	0	1,057
1931	0	0	7	47	20	40	13	10	0	0	0	0	138
1932	0	0	504	251	485	75	53	26	8	1	0	0	1,403
1933	0	0	5	114	37	88	60	40	2	0	0	0	346
1934	0	0	141	204	208	94	29	14	4	0	0	0	693
1935	0	5	15	561	38	238	502	117	12	2	0	0	1,489
1936	0	0	15	109	904	184	186	71	12	2	0	0	1,482
1937	0	0	11	47	733	1,023	326	99	15	4	1	0	2,259
1938	0	2	296	321	1,710	1,342	386	120	23	9	3	1	4,213
1939	2	17	66	47	103	145	46	19	5	0	0	0	449
1940	0	0	4	566	1,260	886	445	99	19	6	2	0	3,287
1941	1	3	273	647	1,306	1,108	1,379	270	28	11	4	2	5,031
1942	2	13	347	996	911	411	604	228	21	7	2	0	3,542
1943	2	61	45	1,074	416	524	197	92	16	5	1	0	2,433
1944	1	8	19	35	356	333	99	58	8	1	0	0	918
1945	0	13	30	74	832	287	130	99	12	2	0	0	1,479
1946	0	19	765	383	162	142	117	73	12	2	0	0	1,674
1947	2	37	42	43	76	172	118	46	7	1	0	0	543
1948	0	2	16	15	21	126	200	95	5	0	0	0	479
1949	0	0	20	23	57	903	120	84	12	2	0	0	1,221
1950	0	0	12	284	317	98	78	39	5	0	0	0	833
1951	0	393	912	430	351	473	112	93	18	5	2	0	2,789
1952	0	6	431	1,602	715	1,121	295	103	24	9	3	1	4,310
1953	2	7	507	749	134	244	102	102	12	2	0	0	1,860
1954	0	23	12	150	301	302	138	57	9	1	0	0	995
1955	0	5	160	269	65	116	83	57	6	0	0	0	762
1956	0	0	1,649	1,106	836	355	145	78	23	9	2	1	4,204
1957	2	5	12	37	381	129	85	121	7	0	0	0	779
1958	0	5	42	275	1,288	1,293	1,895	227	29	11	4	2	5,070
1959	2	4	14	160	542	101	54	32	5	0	0	0	914
1960	0	0	5	40	271	42	33	26	2	0	0	0	418
1961	0	12	12	26	21	103	23	18	1	0	0	0	217
1962	0	0	10	12	767	343	78	61	9	1	0	0	1,281
1963	51	2	37	801	1,089	362	697	340	23	8	2	1	3,412
1964	5	77	29	261	36	68	52	34	4	0	0	0	565
1965	0	17	820	1,364	225	107	541	104	19	6	2	0	3,203
1966	2	80	174	142	204	104	20	23	5	0	0	0	755
1967	0	14	238	914	364	811	804	356	21	7	2	0	3,532
1968	2	5	30	378	183	197	102	57	7	0	0	0	960
1969	0	7	96	1,324	1,479	613	214	75	24	7	2	1	3,841
1970	2	5	38	874	174	576	82	42	9	2	0	0	1,805
1971	0	82	657	307	43	192	115	52	13	2	0	0	1,464
1972	0	1	142	44	83	30	22	10	0	0	0	0	333
1973	0	256	96	909	1,483	824	178	68	18	6	2	1	3,842
1974	8	158	698	674	78	683	690	113	31	15	3	0	3,149
1975	3	11	35	71	1,082	1,330	392	111	27	13	6	5	3,086
1976	5	8	10	9	11	44	18	8	0	0	0	0	112
1977	0	0	4	18	8	26	13	9	0	0	0	0	78
1978	0	0	45	1,043	641	833	354	94	25	7	2	1	3,044
1979	0	3	9	192	583	346	126	44	6	2	0	0	1,311
1980	1	13	117	938	1,674	435	180	74	20	9	2	0	3,463
1981	0	1	12	480	70	471	101	37	5	0	0	0	1,178
1982	0	111	211	1,095	716	560	1,698	253	26	10	3	1	4,686
1983	2	99	469	1,374	1,619	2,866	683	464	42	18	8	4	7,648
1984	9	224	926	122	63	117	103	88	13	3	0	0	1,667
1985	1	146	55	27	124	214	33	34	7	1	0	0	643
1986	0	4	18	17	1,898	1,267	240	85	21	7	2	0	3,559
1987	0	0	9	16	51	75	26	9	0	0	0	0	186
1988	0	0	34	65	15	18	23	10	0	0	0	0	165
1989	0	0	15	16	14	91	24	7	0	0	0	0	167
1990	0	15	12	37	43	41	20	16	0	0	0	0	183
1991	0	0	9	8	7	492	76	26	4	0	0	0	621
1992	0	0	19	27	790	230	96	33	9	1	0	0	1,204
1993	0	0	65	1,054	933	455	151	99	16	5	1	0	2,778
1994	1	4	31	24	293	70	51	44	2	0	0	0	520
1995	0	4	19	1,569	200	2,039	295	149	56	27	9	5	4,375
1996	3	3	78	774	1,315	727	143	101	32	10	2	2	3,190
1997	3	256	1,100	1,972	204	114	64	36	12	5	2	2	3,770
1998	2	36	103	1,084	2,611	612	566	239	97	46	20	11	5,427
1999	11	19	44	256	709	290	419	124	44	13	7	1	1,938
2000	1	8	12	178	956	624	103	53	16	7	1	3	1,960
2001	2	6	13	58	443	409	110	35	5	0	0	0	1,081
2002	0	5	260	152	71	259	74	34	6	0	0	0	862
Avg (21-02)	2	30	179	409	530	432	236	80	14	4	1	1	1,918
Max (21-02)	51	393	1,649	1,972	2,611	2,866	1,895	464	97	46	20	11	7,648
Min (21-02)	0	0	0	0	0	0	1	0	0	0	0	0	1

**Table 4.1.2.8-1
Inflow to San Antonio Reservoir (Acre-feet)**

Water Year	Oct	Nov	Dec	Jan	Feb	Mar	Apr	May	Jun	Jul	Aug	Sep	WY Total
1921	0	0	1,513	3,772	2,044	715	399	316	86	0	0	0	8,845
1922	0	0	1,182	973	6,979	2,787	872	181	40	3	0	0	13,015
1923	0	77	2,274	1,706	1,135	276	442	61	3	0	0	0	5,975
1924	0	0	0	0	0	0	3	0	0	0	0	0	3
1925	0	0	141	120	2,308	307	457	132	25	0	0	0	3,489
1926	0	0	0	6	3,459	224	1,028	25	0	0	0	0	4,741
1927	0	298	325	783	3,311	1,080	1,099	353	147	0	0	0	7,396
1928	0	0	371	525	776	3,278	1,424	83	28	12	0	0	6,497
1929	0	18	153	144	270	463	58	12	3	0	0	0	1,123
1930	0	0	68	678	427	2,535	227	144	95	0	0	0	4,174
1931	0	0	28	184	80	160	52	40	0	0	0	0	543
1932	0	0	1,992	991	1,915	298	209	104	31	3	0	0	5,542
1933	0	0	21	451	144	347	236	160	6	0	0	0	1,366
1934	0	0	555	804	822	371	114	55	15	0	0	0	2,737
1935	0	18	58	2,216	150	939	1,983	463	46	6	0	0	5,880
1936	0	0	58	430	3,572	727	733	279	46	9	0	0	5,855
1937	0	0	43	184	2,894	4,042	1,289	393	58	15	3	0	8,921
1938	0	6	1,169	1,267	6,755	5,300	1,525	476	92	34	12	3	16,640
1939	6	68	261	184	408	571	181	77	18	0	0	0	1,774
1940	0	0	15	2,234	4,978	3,502	1,758	393	74	25	6	0	12,985
1941	3	12	1,080	2,556	5,159	4,376	5,447	1,065	110	43	15	6	19,874
1942	6	52	1,369	3,934	3,600	1,623	2,385	902	83	28	9	0	13,991
1943	6	242	178	4,241	1,642	2,068	779	365	64	18	3	0	9,609
1944	3	31	74	138	1,406	1,317	393	230	31	3	0	0	3,624
1945	0	52	120	292	3,287	1,135	513	390	46	9	0	0	5,843
1946	0	74	3,020	1,513	641	562	460	288	46	9	0	0	6,613
1947	6	144	166	169	301	681	466	181	28	3	0	0	2,145
1948	0	9	61	58	83	497	789	374	18	0	0	0	1,890
1949	0	0	80	89	227	3,566	476	331	46	6	0	0	4,821
1950	0	0	49	1,120	1,252	387	310	153	18	0	0	0	3,290
1951	0	1,553	3,603	1,697	1,387	1,869	442	368	71	21	6	0	11,017
1952	0	25	1,703	6,328	2,823	4,428	1,166	408	95	34	12	3	17,026
1953	6	28	2,001	2,958	528	964	402	402	49	9	0	0	7,347
1954	0	92	49	592	1,191	1,194	546	227	37	3	0	0	3,931
1955	0	21	632	1,062	258	457	328	227	25	0	0	0	3,011
1956	0	0	6,515	4,370	3,302	1,402	571	307	92	34	9	3	16,606
1957	6	21	46	147	1,504	509	338	479	28	0	0	0	3,078
1958	0	18	166	1,086	5,088	5,107	7,485	896	114	43	15	6	20,025
1959	6	15	55	632	2,139	399	215	126	21	0	0	0	3,609
1960	0	0	21	157	1,071	166	129	101	6	0	0	0	1,651
1961	0	49	46	104	83	408	92	71	3	0	0	0	856
1962	0	0	40	49	3,029	1,356	310	239	34	3	0	0	5,061
1963	199	9	144	3,164	4,303	1,430	2,753	1,341	89	31	9	3	13,476
1964	18	304	114	1,031	141	267	206	135	15	0	0	0	2,231
1965	0	68	3,238	5,386	887	424	2,136	411	74	25	6	0	12,653
1966	6	316	687	562	807	411	80	92	21	0	0	0	2,983
1967	0	55	939	3,612	1,439	3,204	3,176	1,406	83	28	9	0	13,951
1968	6	21	117	1,491	724	776	402	227	28	0	0	0	3,793
1969	0	28	377	5,229	5,840	2,421	847	298	95	28	6	3	15,173
1970	9	21	150	3,453	687	2,277	322	166	37	6	0	0	7,129
1971	0	325	2,596	1,212	169	758	454	206	52	9	0	0	5,782
1972	0	3	562	175	328	120	86	40	0	0	0	0	1,313
1973	0	1,013	381	3,591	5,859	3,256	703	270	71	25	6	3	15,176
1974	31	623	2,756	2,661	307	2,698	2,725	445	123	58	12	0	12,438
1975	12	43	138	279	4,275	5,254	1,547	439	107	52	25	18	12,190
1976	18	31	40	37	43	172	71	31	0	0	0	0	442
1977	0	0	15	71	31	104	52	37	0	0	0	0	310
1978	0	0	178	4,118	2,532	3,290	1,399	371	98	28	6	3	12,024
1979	0	12	37	758	2,305	1,366	497	175	25	6	0	0	5,180
1980	3	52	460	3,704	6,613	1,719	712	292	80	34	9	0	13,678
1981	0	3	49	1,897	276	1,860	399	147	21	0	0	0	4,652
1982	0	439	835	4,327	2,830	2,213	6,706	1,000	104	40	12	3	18,509
1983	6	393	1,854	5,429	6,396	11,321	2,698	1,832	166	71	31	15	30,210
1984	34	884	3,658	482	249	460	405	347	52	12	0	0	6,583
1985	3	577	218	107	491	847	132	135	28	3	0	0	2,541
1986	0	15	71	68	7,497	5,005	948	335	83	28	9	0	14,059
1987	0	0	37	64	203	298	101	34	0	0	0	0	737
1988	0	0	135	258	58	71	89	40	0	0	0	0	651
1989	0	0	58	64	55	359	95	28	0	0	0	0	660
1990	0	58	46	144	169	163	80	61	0	0	0	0	721
1991	0	0	34	31	28	1,943	301	101	15	0	0	0	2,452
1992	0	0	74	107	3,121	908	381	129	34	3	0	0	4,757
1993	0	0	258	4,164	3,686	1,795	595	390	64	18	3	0	10,974
1994	3	15	123	95	1,157	276	199	175	9	0	0	0	2,053
1995	0	15	77	6,199	792	8,056	1,166	589	221	107	37	21	17,281
1996	12	12	307	3,057	5,193	2,872	565	399	126	40	9	9	12,601
1997	12	1,013	4,346	7,789	804	451	255	141	46	18	6	9	14,890
1998	9	141	408	4,281	10,311	2,418	2,237	942	384	181	80	43	21,436
1999	43	77	175	1,013	2,802	1,145	1,654	488	175	52	28	3	7,654
2000	3	31	46	703	3,775	2,464	408	209	61	28	3	12	7,743
2001	9	25	52	230	1,749	1,614	436	138	18	0	0	0	4,272
2002	0	21	1,028	598	282	1,022	292	135	25	0	0	0	3,403
Avg (21-02)	6	117	709	1,617	2,093	1,706	932	318	55	16	5	2	7,575
Max (21-02)	199	1,553	6,515	7,789	10,311	11,321	7,485	1,832	384	181	80	43	30,210
Min (21-02)	0	0	0	0	0	0	3	0	0	0	0	0	3

4.1.2.9 Inflow to Crystal Springs Reservoir

Crystal Springs Reservoir receives inflow from its own watershed on San Mateo Creek, transfers of water from Pilarcitos Creek, and transfers from Hetch Hetchy and the East Bay watersheds. Inflow to Crystal Springs Reservoir from its watershed is depicted in Table 4.1.2.9-1. The average annual inflow to Crystal Springs Reservoir is estimated to be 11,400 acre-feet. Inflow to the reservoir from the other sources is an operational result and can vary in each study.

4.1.2.10 Inflow to San Andreas Reservoir

San Andreas Reservoir receives inflow from its own watershed and transfers from San Mateo Creek and Pilarcitos Creek. The reservoir also receives inflow from pumping from Crystal Springs Reservoir. Table 4.1.2.10-1 depicts the estimated inflow to San Andreas Reservoir from its watershed. The average annual runoff is estimated to be 4,400 acre-feet. Inflow to the reservoir from the other sources is an operational result and can vary in each study.

4.1.2.11 Inflow to Pilarcitos Reservoir

Located in the upper Pilarcitos Creek watershed, Pilarcitos Reservoir receives runoff averaging 4,000 acre-feet per year. Table 4.1.2.11-1 depicts the estimated inflow to Pilarcitos Reservoir. The inflow has ranged from essentially none during an extreme drought year such as 1924, to over 15,800 acre-feet in 1983.

4.1.2.12 Unregulated Runoff below Pilarcitos Reservoir

Unregulated tributary flow occurs between Pilarcitos Dam and Stone Dam. This water is available for diversion at Stone Dam in addition to the flows being released from Pilarcitos Dam. Table 4.1.2.12-1 depicts this unregulated runoff. The unregulated runoff in this reach of stream is estimated to be an average annual 1,800 acre-feet.

**Table 4.1.2.9-1
Inflow to Crystal Springs Reservoir from Watershed (Acre-feet)**

Water Year	Oct	Nov	Dec	Jan	Feb	Mar	Apr	May	Jun	Jul	Aug	Sep	WY Total
1921	12	181	3,032	4,293	2,289	632	270	172	52	34	18	12	10,999
1922	18	21	1,725	1,056	8,866	4,131	1,445	402	92	49	28	18	17,852
1923	31	190	4,478	2,372	2,010	417	1,310	184	89	34	18	12	11,146
1924	0	0	0	0	0	0	3	0	0	0	0	0	3
1925	6	15	374	353	3,290	227	491	509	55	18	12	9	5,361
1926	12	15	31	365	6,521	491	1,832	129	80	28	15	12	9,532
1927	18	1,479	485	1,280	6,083	1,660	2,096	252	101	40	21	15	13,531
1928	25	25	951	485	911	5,837	2,234	224	9	34	18	12	10,766
1929	18	21	853	654	663	948	399	110	52	15	9	6	3,750
1930	12	15	31	862	862	3,569	292	135	31	18	12	9	5,849
1931	21	21	52	365	157	187	61	46	25	12	9	9	967
1932	9	12	2,934	1,571	2,833	353	249	123	71	25	15	9	8,203
1933	25	25	43	835	285	411	282	187	40	15	12	9	2,170
1934	9	15	976	1,317	1,341	442	132	64	49	15	12	9	4,382
1935	15	55	114	3,244	298	1,191	2,691	549	92	31	18	12	8,311
1936	21	28	117	804	5,420	890	896	331	92	34	18	12	8,663
1937	21	21	83	362	4,207	5,650	1,697	463	114	43	25	18	12,705
1938	21	40	1,814	1,949	11,122	7,457	2,035	562	160	71	37	25	25,291
1939	64	123	513	359	776	675	215	92	55	21	15	12	2,922
1940	9	15	31	3,265	7,939	4,873	2,369	463	132	55	31	21	19,205
1941	31	46	1,694	3,704	8,265	6,132	7,666	1,375	184	83	43	28	29,250
1942	46	101	2,084	6,073	5,469	2,179	3,268	1,142	144	61	34	21	20,623
1943	40	371	350	6,620	2,458	2,817	964	433	120	46	28	18	14,264
1944	31	74	144	273	2,136	1,734	466	270	74	25	15	12	5,254
1945	15	104	236	574	4,910	1,476	605	460	95	34	18	15	8,544
1946	18	135	4,431	2,280	1,096	663	543	341	92	34	18	15	9,667
1947	34	236	325	331	589	822	552	212	71	25	18	12	3,228
1948	18	40	120	117	163	586	976	445	55	21	15	12	2,569
1949	12	18	160	172	448	4,969	565	393	92	31	18	12	6,890
1950	15	18	95	1,746	1,927	457	368	184	55	18	12	9	4,907
1951	15	2,231	5,475	2,532	2,111	2,529	522	433	129	52	28	18	16,075
1952	25	64	2,544	10,361	4,082	6,205	1,519	482	163	71	37	25	25,576
1953	46	64	2,949	4,324	939	1,228	476	476	98	37	21	15	10,674
1954	28	160	95	1,028	1,844	1,559	644	267	80	28	15	12	5,760
1955	18	58	1,080	1,669	506	540	390	267	61	21	12	9	4,634
1956	12	25	10,692	6,850	4,938	1,860	675	365	160	71	37	25	25,708
1957	58	61	92	292	2,271	605	399	565	68	21	15	12	4,459
1958	12	52	325	1,700	8,139	7,181	10,594	1,129	187	83	43	31	29,477
1959	49	52	107	1,080	3,133	470	255	147	58	18	12	9	5,392
1960	15	15	40	307	1,682	196	150	120	37	12	9	6	2,590
1961	15	98	89	209	160	485	110	83	34	15	12	9	1,320
1962	9	15	80	95	4,447	1,792	365	282	77	25	15	12	7,215
1963	18	43	282	4,689	6,730	1,900	3,796	1,771	153	64	34	25	19,506
1964	40	460	224	1,627	279	316	242	163	49	18	12	9	3,440
1965	12	126	4,821	8,670	1,430	500	2,912	485	135	55	31	21	19,199
1966	37	479	1,157	985	1,320	488	95	107	58	18	12	9	4,766
1967	12	107	1,498	5,493	2,182	4,447	4,407	1,863	144	61	34	21	20,270
1968	40	58	227	2,253	1,206	961	476	267	71	25	15	12	5,610
1969	15	68	733	8,393	9,486	3,324	1,062	350	166	58	28	28	23,710
1970	43	58	298	5,211	1,154	3,115	381	196	83	31	21	18	10,609
1971	18	491	3,762	1,875	335	933	534	242	101	34	15	12	8,354
1972	21	34	985	344	644	141	101	46	28	12	3	6	2,366
1973	15	1,464	737	5,453	9,520	4,520	853	319	129	55	28	28	23,121
1974	80	911	3,977	3,845	605	3,716	3,759	525	199	104	37	15	17,775
1975	49	89	273	552	6,678	7,390	2,065	519	178	95	58	46	17,993
1976	61	71	83	74	83	206	83	37	15	9	9	9	740
1977	28	28	31	138	58	123	61	43	18	6	6	6	546
1978	6	15	347	6,402	3,673	4,570	1,854	439	169	58	31	28	17,591
1979	28	49	71	1,252	3,364	1,808	589	209	61	28	15	12	7,485
1980	34	101	847	5,659	10,870	2,311	868	344	141	68	34	21	21,298
1981	25	34	98	2,808	546	2,516	473	175	58	15	9	6	6,764
1982	12	651	1,356	6,773	4,091	3,023	9,477	1,280	175	77	40	28	26,982
1983	37	586	2,750	8,749	10,477	16,106	3,716	2,474	264	123	61	43	45,386
1984	86	1,286	5,573	875	491	543	479	411	101	37	21	15	9,919
1985	31	850	430	212	887	1,059	153	160	68	25	15	12	3,901
1986	12	49	138	132	12,454	7,034	1,206	396	147	61	34	15	21,679
1987	21	25	74	129	399	353	120	40	25	9	6	6	1,206
1988	9	25	264	509	117	83	104	46	25	9	6	6	1,203
1989	9	15	114	126	110	424	114	34	25	9	6	6	991
1990	9	114	89	285	335	193	95	71	28	12	9	6	1,246
1991	6	28	92	83	77	2,750	439	147	40	21	9	6	3,698
1992	12	15	144	209	4,628	1,151	451	153	77	25	15	12	6,893
1993	15	15	513	6,503	5,644	2,434	706	460	123	49	28	18	16,508
1994	34	49	242	187	1,805	325	236	209	43	15	9	9	3,164
1995	6	52	150	10,164	1,304	11,456	1,525	697	344	172	74	49	25,994
1996	49	46	608	4,514	8,357	3,983	672	473	209	77	37	34	19,058
1997	49	1,470	6,831	13,021	1,320	534	304	169	95	49	31	34	23,907
1998	40	227	776	6,718	17,557	3,330	3,069	1,203	574	279	132	83	33,988
1999	104	138	344	1,605	4,054	1,491	2,228	580	279	95	61	28	11,008
2000	34	71	89	1,182	5,806	3,397	485	249	117	61	28	37	11,554
2001	46	61	104	454	2,615	2,173	516	163	55	25	15	12	6,239
2002	12	61	1,630	1,037	555	1,317	344	160	64	15	9	6	5,211
Avg (21-02)	26	206	1,154	2,528	3,303	2,353	1,270	397	102	43	23	17	11,421
Max (21-02)	104	2,231	10,692	13,021	17,557	16,106	10,594	2,474	574	279	132	83	45,386
Min (21-02)	0	0	0	0	0	0	3	0	0	0	0	0	3

**Table 4.1.2.10-1
Inflow to San Andreas Reservoir from Watershed (Acre-feet)**

Water Year	Oct	Nov	Dec	Jan	Feb	Mar	Apr	May	Jun	Jul	Aug	Sep	WY Total
1921	6	68	1,163	1,648	878	242	104	68	21	12	6	6	4,223
1922	6	9	663	405	3,403	1,587	555	153	37	18	9	6	6,853
1923	12	74	1,719	911	770	160	503	71	34	12	6	6	4,278
1924	0	0	0	0	0	0	0	0	0	0	0	0	0
1925	3	6	144	135	1,261	86	187	196	21	6	3	3	2,053
1926	6	6	12	141	2,504	190	703	49	31	12	6	6	3,667
1927	6	568	187	491	2,335	638	804	98	40	15	9	6	5,199
1928	9	9	365	187	350	2,240	856	86	3	12	6	6	4,131
1929	6	9	328	252	255	362	153	43	21	6	3	3	1,442
1930	3	6	12	331	331	1,369	110	52	12	6	6	3	2,243
1931	9	9	21	141	58	74	25	18	9	3	3	3	374
1932	3	6	1,126	602	1,086	135	95	46	28	9	6	3	3,146
1933	9	9	15	319	110	157	107	71	15	6	3	3	826
1934	3	6	374	506	516	169	52	25	18	6	3	3	1,682
1935	6	21	43	1,243	114	457	1,034	212	37	12	6	6	3,192
1936	9	9	46	307	2,081	341	344	126	37	12	6	6	3,324
1937	9	9	31	138	1,614	2,167	651	178	43	15	9	6	4,870
1938	9	15	697	746	4,269	2,863	779	215	61	28	15	9	9,707
1939	25	46	196	138	298	258	83	37	21	9	6	3	1,120
1940	3	6	12	1,255	3,047	1,869	908	178	52	21	12	9	7,375
1941	12	18	651	1,421	3,170	2,354	2,943	528	71	31	15	12	11,226
1942	18	40	801	2,329	2,099	835	1,255	439	55	25	12	9	7,918
1943	15	141	135	2,541	942	1,080	371	166	46	18	9	6	5,472
1944	12	28	55	104	819	666	178	104	28	9	6	3	2,013
1945	6	40	92	221	1,884	568	233	178	37	12	6	6	3,284
1946	6	52	1,700	875	420	255	209	132	37	12	6	6	3,710
1947	12	89	126	129	227	316	212	83	28	9	6	6	1,243
1948	6	15	46	43	61	224	374	169	21	9	6	3	979
1949	6	6	61	68	172	1,906	215	150	37	12	6	6	2,645
1950	6	6	37	672	740	175	141	71	21	6	3	3	1,881
1951	6	856	2,102	973	810	970	199	166	49	18	12	6	6,168
1952	9	25	976	3,977	1,565	2,381	583	184	61	28	15	9	9,814
1953	18	25	1,132	1,660	362	470	181	184	37	12	9	6	4,097
1954	9	61	37	393	709	598	249	101	31	9	6	6	2,210
1955	6	21	414	641	193	209	150	104	25	9	6	3	1,783
1956	3	9	4,103	2,630	1,894	715	258	141	61	28	15	9	9,867
1957	21	25	37	110	872	230	153	218	25	9	6	3	1,709
1958	3	21	126	654	3,124	2,756	4,066	433	74	31	15	12	11,315
1959	18	18	40	414	1,203	181	98	58	21	6	6	3	2,068
1960	6	6	15	117	644	77	58	46	12	6	3	3	994
1961	6	37	34	80	61	184	43	31	12	6	3	3	500
1962	3	6	31	37	1,706	687	141	107	31	9	6	3	2,768
1963	6	15	107	1,798	2,584	730	1,458	681	58	25	12	9	7,485
1964	15	175	86	623	107	120	95	61	18	6	3	3	1,313
1965	3	49	1,851	3,327	549	193	1,117	187	52	21	12	9	7,371
1966	12	184	445	377	506	187	37	40	21	6	6	3	1,826
1967	6	40	574	2,108	838	1,706	1,691	715	55	25	12	9	7,780
1968	15	21	89	865	463	368	181	101	28	9	6	3	2,151
1969	6	28	282	3,219	3,640	1,277	408	135	64	21	12	9	9,102
1970	18	21	114	1,998	442	1,194	147	77	31	12	9	6	4,069
1971	6	187	1,442	718	129	359	206	92	40	12	6	6	3,204
1972	9	12	377	132	249	55	40	18	12	3	0	3	911
1973	6	562	282	2,093	3,652	1,734	328	123	49	21	12	9	8,872
1974	31	350	1,525	1,476	233	1,427	1,442	203	77	40	15	6	6,825
1975	18	34	104	212	2,563	2,836	792	199	68	37	21	18	6,902
1976	25	28	31	28	31	80	31	15	6	3	3	3	282
1977	9	12	12	52	21	46	25	18	6	3	3	3	212
1978	3	6	135	2,458	1,409	1,752	712	169	64	21	12	9	6,752
1979	9	18	28	482	1,292	694	227	80	25	12	6	6	2,879
1980	12	40	325	2,173	4,171	887	335	132	55	25	12	9	8,176
1981	9	12	37	1,077	209	967	181	68	21	6	3	3	2,593
1982	3	249	519	2,599	1,571	1,160	3,637	491	68	31	15	9	10,351
1983	15	224	1,056	3,357	4,020	6,181	1,427	948	101	46	25	15	17,416
1984	34	494	2,139	335	187	209	184	157	40	15	9	6	3,809
1985	12	325	166	80	341	405	58	61	28	9	6	6	1,498
1986	3	18	52	49	4,778	2,698	463	153	55	25	12	6	8,314
1987	9	9	28	49	153	135	46	15	9	3	3	3	463
1988	3	9	101	196	43	31	40	18	9	3	3	3	460
1989	3	6	43	49	43	163	43	12	9	3	3	3	381
1990	3	43	34	110	129	74	37	28	9	3	3	3	476
1991	3	12	34	31	31	1,056	169	58	15	9	3	3	1,424
1992	6	6	55	80	1,771	442	172	58	31	9	6	3	2,639
1993	6	6	196	2,489	2,161	930	270	178	46	18	9	6	6,316
1994	12	18	92	71	691	126	92	80	15	6	3	3	1,209
1995	3	18	58	3,891	500	4,385	583	267	132	68	28	18	9,952
1996	18	18	233	1,728	3,198	1,525	258	181	80	31	12	12	7,295
1997	18	562	2,615	4,984	506	206	117	64	37	18	12	12	9,151
1998	15	86	298	2,572	6,721	1,274	1,175	460	218	107	52	34	13,012
1999	40	52	132	614	1,553	571	853	221	107	37	25	9	4,214
2000	12	28	34	451	2,222	1,301	184	95	43	25	9	15	4,419
2001	18	25	40	175	1,000	832	196	61	21	9	6	3	2,388
2002	6	25	623	399	212	503	132	61	25	6	3	3	1,998
Avg (21-02)	10	79	443	970	1,267	903	487	152	39	16	9	7	4,381
Max (21-02)	40	856	4,103	4,984	6,721	6,181	4,066	948	218	107	52	34	17,416
Min (21-02)	0	0	0	0	0	0	0	0	0	0	0	0	0

**Table 4.1.2.11-1
Inflow to Pilarcitos Reservoir (Acre-feet)**

Water Year	Oct	Nov	Dec	Jan	Feb	Mar	Apr	May	Jun	Jul	Aug	Sep	WY Total
1921	3	61	1,059	1,498	798	221	95	61	18	12	6	6	3,839
1922	6	6	602	368	3,093	1,439	503	141	34	18	9	6	6,227
1923	9	64	1,562	829	700	144	457	64	31	12	6	6	3,885
1924	0	0	0	0	0	0	0	0	0	0	0	0	0
1925	3	6	132	123	1,148	80	172	178	18	6	3	3	1,872
1926	6	6	9	129	2,274	172	638	46	28	9	6	3	3,327
1927	6	516	169	445	2,121	580	730	89	37	12	6	6	4,717
1928	9	9	331	169	319	2,035	779	80	3	12	6	6	3,759
1929	6	6	298	227	230	331	138	40	18	6	3	3	1,307
1930	3	6	12	301	301	1,246	101	46	9	6	3	3	2,038
1931	6	9	18	126	55	64	21	15	9	3	3	3	335
1932	3	6	1,022	546	988	123	86	43	25	9	6	3	2,860
1933	9	9	15	292	98	144	98	64	12	6	3	3	755
1934	3	6	341	460	466	153	46	21	18	6	3	3	1,528
1935	6	18	40	1,129	104	414	939	190	31	12	6	6	2,897
1936	6	9	40	279	1,890	310	313	117	31	12	6	6	3,020
1937	6	6	28	126	1,467	1,970	592	163	40	15	9	6	4,428
1938	6	12	632	678	3,879	2,599	709	196	55	25	12	9	8,814
1939	21	43	178	126	270	236	77	34	18	6	6	3	1,019
1940	3	6	9	1,139	2,768	1,700	826	163	46	18	9	6	6,693
1941	9	15	589	1,292	2,882	2,139	2,673	479	64	28	15	9	10,195
1942	15	37	727	2,118	1,906	758	1,139	399	49	21	12	9	7,190
1943	12	129	123	2,308	856	982	338	150	43	15	9	6	4,972
1944	12	25	49	95	746	605	163	95	25	9	6	3	1,832
1945	6	37	83	199	1,712	516	212	160	34	12	6	6	2,983
1946	6	46	1,547	795	381	230	190	120	34	12	6	6	3,373
1947	12	83	114	117	206	285	193	74	25	9	6	6	1,129
1948	6	12	43	40	55	206	341	153	18	6	6	3	890
1949	6	6	55	61	157	1,731	196	138	31	9	6	6	2,403
1950	6	6	34	611	672	160	129	64	18	6	3	3	1,712
1951	6	779	1,909	884	737	881	181	150	46	18	9	6	5,607
1952	9	21	887	3,612	1,424	2,164	531	169	55	25	12	9	8,918
1953	15	21	1,028	1,507	328	427	166	166	34	12	6	6	3,716
1954	9	55	34	359	641	543	224	92	28	9	6	6	2,004
1955	6	21	377	583	175	187	135	95	21	6	6	3	1,617
1956	3	9	3,729	2,388	1,722	648	236	126	55	25	12	9	8,961
1957	18	21	34	101	792	212	138	196	25	9	6	3	1,556
1958	3	18	114	592	2,839	2,504	3,695	393	64	31	15	9	10,278
1959	18	18	37	377	1,093	163	89	52	21	6	3	3	1,881
1960	6	6	15	107	586	68	52	40	12	6	3	3	905
1961	6	34	31	74	55	169	37	28	12	6	3	3	457
1962	3	6	28	34	1,550	626	129	98	28	9	6	3	2,520
1963	6	15	98	1,636	2,348	663	1,323	617	55	21	12	9	6,804
1964	15	160	80	568	98	110	86	55	18	6	3	3	1,203
1965	3	43	1,682	3,023	497	175	1,016	169	46	18	9	6	6,687
1966	12	166	402	344	460	169	34	37	21	6	3	3	1,657
1967	3	37	522	1,915	761	1,550	1,538	651	52	21	12	9	7,071
1968	12	21	80	786	420	335	166	92	25	9	6	3	1,955
1969	6	25	255	2,928	3,308	1,160	371	123	58	21	9	9	8,274
1970	15	21	104	1,817	402	1,086	132	68	28	12	6	6	3,698
1971	6	172	1,310	654	117	325	187	83	34	12	6	3	2,909
1972	6	12	344	120	224	49	34	15	9	3	0	3	819
1973	6	509	258	1,903	3,321	1,577	298	110	46	18	9	9	8,065
1974	28	316	1,387	1,341	212	1,295	1,310	184	71	37	12	6	6,199
1975	18	31	95	193	2,329	2,578	721	181	61	34	21	15	6,279
1976	21	25	28	25	28	71	28	12	6	3	3	3	252
1977	9	9	12	49	21	43	21	15	6	3	3	3	196
1978	3	6	123	2,231	1,280	1,593	648	153	58	21	9	9	6,135
1979	9	15	25	436	1,172	629	206	74	21	9	6	3	2,605
1980	12	34	295	1,973	3,790	807	304	120	49	25	12	6	7,427
1981	9	12	34	979	190	878	166	61	21	6	3	3	2,363
1982	3	227	473	2,360	1,427	1,056	3,305	448	61	28	15	9	9,412
1983	12	206	957	3,050	3,655	5,616	1,295	862	92	43	21	15	15,826
1984	31	448	1,943	304	172	190	166	144	37	12	6	6	3,459
1985	9	295	150	74	310	368	55	55	25	9	6	3	1,360
1986	3	18	49	46	4,342	2,452	420	138	52	21	12	6	7,562
1987	6	9	25	46	138	123	40	12	9	3	3	3	417
1988	3	9	92	178	40	31	37	15	9	3	3	3	424
1989	3	6	40	43	40	147	40	12	9	3	3	3	350
1990	3	40	31	98	117	68	34	25	9	3	3	3	433
1991	3	9	31	31	28	957	153	52	15	6	3	3	1,292
1992	3	6	49	74	1,608	399	157	52	28	9	6	3	2,394
1993	6	6	178	2,259	1,961	844	246	160	43	18	9	6	5,736
1994	12	18	83	64	626	114	83	74	15	6	3	3	1,102
1995	3	18	52	3,532	454	3,980	531	242	120	61	25	18	9,038
1996	15	15	212	1,568	2,903	1,384	233	163	74	28	12	12	6,620
1997	18	509	2,372	4,524	457	187	104	58	34	15	9	12	8,301
1998	15	80	270	2,332	6,101	1,157	1,065	417	199	95	46	31	11,809
1999	37	49	120	559	1,409	519	773	203	95	34	21	9	3,827
2000	12	25	31	411	2,016	1,182	169	86	40	21	9	12	4,014
2001	15	21	37	157	908	755	178	55	18	9	6	3	2,164
2002	6	21	565	362	193	457	120	55	21	6	3	3	1,814
Avg (21-02)	9	72	402	881	1,151	820	443	138	36	15	8	6	3,980
Max (21-02)	37	779	3,729	4,524	6,101	5,616	3,695	862	199	95	46	31	15,826
Min (21-02)	0	0	0	0	0	0	0	0	0	0	0	0	0

**Table 4.1.2.12-1
Unregulated Runoff below Pilarcitos Reservoir (Acre-feet)**

Water Year	Oct	Nov	Dec	Jan	Feb	Mar	Apr	May	Jun	Jul	Aug	Sep	WY Total
1921	0	28	491	697	371	101	43	28	9	6	3	3	1,780
1922	3	3	279	172	1,439	669	233	64	15	9	3	3	2,894
1923	3	31	727	387	325	68	212	31	15	6	3	3	1,811
1924	0	0	0	0	0	0	0	0	0	0	0	0	0
1925	0	3	61	58	534	37	80	83	9	3	0	0	868
1926	3	3	3	61	1,059	80	298	21	12	3	3	0	1,547
1927	3	239	80	206	985	270	341	40	18	6	3	3	2,194
1928	3	3	153	80	147	945	362	37	0	6	3	3	1,743
1929	3	3	138	104	107	153	64	18	9	3	0	0	605
1930	0	3	6	141	141	580	46	21	3	3	0	0	945
1931	3	3	9	58	25	31	9	6	3	0	0	0	147
1932	0	3	476	255	460	58	40	21	12	3	3	0	1,332
1933	3	3	6	135	46	68	46	31	6	3	0	0	347
1934	0	3	160	215	218	71	21	9	9	3	0	0	709
1935	3	9	18	525	49	193	436	89	15	6	3	3	1,350
1936	3	3	18	129	878	144	144	55	15	6	3	3	1,402
1937	3	3	12	58	681	918	276	77	18	6	3	3	2,059
1938	3	6	295	316	1,805	1,209	328	92	25	12	6	3	4,100
1939	9	21	83	58	126	110	37	15	9	3	3	0	476
1940	0	3	3	531	1,286	792	384	77	21	9	3	3	3,112
1941	3	6	273	602	1,341	994	1,243	224	31	12	6	3	4,738
1942	6	18	338	985	887	353	531	184	21	9	6	3	3,342
1943	6	61	58	1,074	399	457	157	71	21	6	3	3	2,317
1944	6	12	21	43	347	282	77	43	12	3	3	0	850
1945	3	18	40	92	795	239	98	74	15	6	3	3	1,387
1946	3	21	718	368	178	107	89	55	15	6	3	3	1,568
1947	6	40	52	55	95	132	89	34	12	3	3	3	525
1948	3	6	21	18	25	95	160	71	9	3	3	0	414
1949	3	3	25	28	74	804	92	64	15	3	3	3	1,117
1950	3	3	15	285	313	74	61	31	9	3	0	0	798
1951	3	362	887	411	344	408	83	71	21	9	3	3	2,605
1952	3	9	411	1,679	663	1,007	246	80	25	12	6	3	4,143
1953	6	9	479	700	153	199	77	77	15	6	3	3	1,728
1954	3	25	15	166	298	252	104	43	12	3	3	0	924
1955	3	9	175	270	83	86	61	43	9	3	3	0	746
1956	0	3	1,734	1,111	801	301	110	58	25	12	6	3	4,164
1957	9	9	15	46	368	98	64	92	12	3	3	0	721
1958	0	9	52	276	1,320	1,163	1,719	184	31	15	6	3	4,778
1959	9	9	18	175	509	77	40	25	9	3	0	0	875
1960	3	3	6	49	273	31	25	18	6	3	0	0	417
1961	3	15	15	34	25	80	18	12	6	3	0	0	212
1962	0	3	12	15	721	292	61	46	12	3	3	0	1,169
1963	3	6	46	761	1,093	307	614	285	25	9	6	3	3,158
1964	6	74	37	264	46	52	40	25	9	3	0	0	555
1965	0	21	783	1,406	230	83	473	80	21	9	3	3	3,112
1966	6	77	187	160	215	80	15	18	9	3	0	0	770
1967	0	18	242	890	353	721	715	304	25	9	6	3	3,287
1968	6	9	37	365	196	157	77	43	12	3	3	0	908
1969	3	12	120	1,363	1,538	540	172	58	28	9	3	3	3,848
1970	6	9	49	844	187	506	61	31	12	6	3	3	1,719
1971	3	80	611	304	55	150	86	40	15	6	3	0	1,353
1972	3	6	160	55	104	21	15	6	3	0	0	0	374
1973	3	236	120	884	1,544	733	138	52	21	9	3	3	3,747
1974	12	147	644	623	98	602	611	86	34	18	6	3	2,885
1975	9	15	43	89	1,083	1,200	335	83	28	15	9	6	2,915
1976	9	12	12	12	12	34	12	6	3	0	0	0	114
1977	3	3	6	21	9	21	9	6	3	0	0	0	83
1978	0	3	58	1,037	595	740	301	71	28	9	3	3	2,848
1979	3	6	12	203	546	292	95	34	9	3	3	0	1,206
1980	6	15	138	918	1,762	374	141	55	21	12	6	3	3,453
1981	3	6	15	454	89	408	77	28	9	3	0	0	1,093
1982	0	104	221	1,099	663	491	1,538	209	28	12	6	3	4,373
1983	6	95	445	1,418	1,700	2,612	602	402	43	21	9	6	7,359
1984	15	209	902	141	80	89	77	68	18	6	3	3	1,611
1985	3	138	71	34	144	172	25	25	12	3	3	0	629
1986	0	9	21	21	2,019	1,142	196	64	25	9	6	3	3,517
1987	3	3	12	21	64	58	18	6	3	0	0	0	190
1988	0	3	43	83	18	15	18	6	3	0	0	0	190
1989	0	3	18	21	18	68	18	6	3	0	0	0	157
1990	0	18	15	46	55	31	15	12	3	0	0	0	196
1991	0	3	15	15	12	445	71	25	6	3	0	0	595
1992	3	3	25	34	749	187	74	25	12	3	3	3	1,120
1993	3	3	83	1,050	911	393	114	74	18	9	3	3	2,664
1994	6	9	40	31	292	52	37	34	6	3	3	0	513
1995	0	9	25	1,642	212	1,851	246	114	55	28	12	9	4,201
1996	9	6	98	730	1,350	644	107	77	34	12	6	6	3,081
1997	9	236	1,105	2,102	215	86	49	28	15	9	6	6	3,867
1998	6	37	126	1,086	2,836	537	497	193	92	46	21	12	5,490
1999	15	21	55	258	654	242	359	95	46	15	9	3	1,774
2000	6	12	15	190	939	549	77	40	18	9	3	6	1,866
2001	6	9	18	74	424	350	83	28	9	3	3	3	1,010
2002	3	9	264	169	89	212	55	25	9	3	0	0	838
Avg (21-02)	4	33	187	410	535	381	206	64	16	7	3	2	1,849
Max (21-02)	15	362	1,734	2,102	2,836	2,612	1,719	402	92	46	21	12	7,359
Min (21-02)	0	0	0	0	0	0	0	0	0	0	0	0	0

4.1.3 Evaporation

Water added to or dissipated from reservoirs due to net evaporation and precipitation is determined dynamically within a study based on the operation of the reservoirs. The underlying net evaporation and precipitation at the reservoirs is represented by 12 monthly factors, constant for each year of the simulation.

For Hetch Hetchy Reservoir, Lake Lloyd, and Lake Eleanor, a set of monthly net evaporation and precipitation factors is used. These factors have been agreed to by San Francisco and the Districts, and are currently used for Tuolumne River flow accounting by the two entities. Table 4.1.3-1 depicts the evaporation factors for SFPUC reservoirs. Also shown are the daily net evaporation factors used for Don Pedro Reservoir. Net evaporation values from Burlingame have been assumed for the Peninsula reservoirs, and net evaporation values for Del Valle Reservoir have been assumed for the Alameda system reservoirs. These values are also shown in Table 4.1.3-1

**Table 4.1.3-1
Net Evaporation Factors for Reservoirs**

	Hetch Hetchy Reservoir Lake Lloyd Lake Eleanor	Don Pedro Reservoir	Crystal Springs Reservoir San Andreas Reservoir Pilarcitos Reservoir	Calaveras Reservoir San Antonio Reservoir
	cfs/[acre*day]	cfs/[acre*day]	Inches	Inches
October	0.00325269	0.00639480	2.88	4.10
November	0	0.00178105	1.50	2.08
December	0	-0.00013449	1.00	1.20
January	-0.00325269	-0.00088458	1.03	1.02
February	-0.00360119	-0.00025777	1.41	1.29
March	0	0.00113491	2.74	2.22
April	0	0.00308124	3.97	3.41
May	0.00325269	0.00796822	5.15	5.15
June	0.00672222	0.01094715	5.89	6.37
July	0.00975807	0.01397570	6.30	7.75
August	0.00975807	0.01410893	5.53	7.32
September	0.00672222	0.01072018	4.30	6.16

Sample computation of reservoir evaporation:
Tuolumne River Reservoirs
Average Evaporation (cfs/day) = Evaporation Rate x Surface Area (acres)
Evaporation (acre-feet) = Average Evaporation (cfs/day) x number of days x 1.98347
Bay Area Reservoirs
Evaporation (acre-feet) = Evaporation (inches) x Surface Area x Conversion

4.2 Facilities

This section describes the facilities modeled by HH/LSM. The facilities are grouped into subsections: Reservoirs, Pipelines and Conveyance Facilities, Power Facilities, and Treatment Facilities.

4.2.1 Reservoirs

As described above, San Francisco manages three major reservoirs in the Tuolumne River Basin and five Bay Area reservoirs. San Francisco also utilizes the Water Bank Account in Don Pedro Reservoir to enhance San Francisco's operations within the Tuolumne River Basin. Table 4.2.1-1 shows the modeled maximum storage of San Francisco's major storage reservoirs, and Don Pedro Reservoir which is operated by the Districts.

**Table 4.2.1-1
Modeled Major Reservoir Storage**

Reservoir/Facility	Maximum Storage (acre-feet)
Hetch Hetchy Reservoir	360,400
Lake Lloyd	273,300
Lake Eleanor	27,100
New Don Pedro Water Bank (Exchange Storage Space)	570,000 (Not including 170,000 acre-feet of conditional storage)
Calaveras Reservoir	96,800 [1]
San Antonio Reservoir	50,600
Crystal Springs Reservoir	69,360 [2]
San Andreas Reservoir	19,000
Pilarcitos Reservoir	2,980
Don Pedro Reservoir (MID/TID)	2,030,000
[1] Currently 37,800 acre-feet interim conditions as required by Division of Safety of Dams	
[2] Currently 58,300 acre-feet interim conditions as required by Division of Safety of Dams	

4.2.1.1 Tuolumne River Reservoirs

A physical relationship exists between a reservoir's storage and surface area, and is based on the topographical characteristics of the reservoir's site. Within the simulation of reservoir operation, the surface area of a reservoir is required for the determination of net evaporation. The surface area-storage relationship for each reservoir is defined by a series of paired values. The model interpolates an area for a computed reservoir storage using these paired values. Table 4.2.1.1-1 depicts the storage and surface area relationship for Hetch Hetchy Reservoir, Lake Lloyd, Lake Eleanor and Don Pedro Reservoir. The computed area is used by the model in estimating the net evaporation of each reservoir for each month of the simulation.

The Hetch Hetchy reservoirs are constrained by maximum storage levels which sometimes vary from month to month. For Hetch Hetchy Reservoir, the maximum storage level is 360,400 acre-feet and is associated with a reservoir level at the top of the spillway drum gates. For the October through March period, a reservoir regulation buffer is modeled. During this period the model attempts to maintain no more than 330,000 acre-feet in storage to reflect a reservoir operation that can regulate most winter-time storms without spill releases below Hetch Hetchy Reservoir.

Cherry Reservoir maximum storage is assumed to vary between 248,000 acre-feet and 273,300 acre-feet. The higher value is allowed to occur during the months of April through June (an assumption that the spillway flash boards are installed). During July, August and September, the maximum storage is modeled to decrease by 10,000 acre-feet per month to draw the reservoir down to 248,000 acre-feet by the end of September. This level of maximum storage is assumed to continue through the end of March. The lower storage is provided as a regulation buffer for winter-time storms. It is assumed that the spillway flash boards are removed during this period of time. Similarly, the maximum allowed storage at Lake Eleanor varies between 21,500 acre-feet (with spillway flash boards removed) and 27,100 acre-feet (with spillway flash boards installed). The spillway flash boards are assumed to be removed during the October through March period.

The maximum amount of available storage in the Water Bank Account varies between a minimum of 570,000 acre-feet (during the flood control season) and a maximum of 740,000 acre-feet. The SFPUC's use of available storage above 570,000 acre-feet is dependent on the Districts' operation of Don Pedro Reservoir. Modeled Water Bank Account storage is normally incidental to upstream operations; however, during drought the model requires specific releases from upstream reservoirs to maintain a greater than zero balance in the account.

Minimum operable or dead storage at Hetch Hetchy Reservoir is assumed to equal 26,100 acre-feet; Lake Lloyd, 1,000 acre-feet; and Lake Eleanor, empty.

Table 4.2.1.1-1

Reservoir Area – Reservoir Storage Relationship for Tuolumne River Reservoirs

Hetch Hetchy Res		Lake Lloyd		Lake Eleanor		Don Pedro Reservoir			
Storage Acre-feet	Area Acres	Storage Acre-feet	Area Acres	Storage Acre-feet	Area Acres	Storage Acre-feet	Area Acres	Storage Acre-feet	Area Acres
0	0	0	0	0	0	0	0	308,960	3,520
410	124	75	8	39	403	35	7	345,310	3,750
3,300	454	250	16	52	413	120	10	384,060	4,000
8,700	634	675	38	82	423	229	12	425,510	4,290
15,400	704	1,530	99	130	429	383	19	469,910	4,590
22,900	793	3,025	243	183	431	617	28	517,450	4,920
31,000	834	6,030	473	211	432	916	32	568,150	5,220
39,500	867	11,745	737	550	446	1,280	41	621,950	5,540
48,300	899	19,740	883	996	460	1,759	55	678,950	5,840
57,400	926	28,885	973	2,450	511	2,401	74	738,950	6,180
66,900	952	38,886	1,047	5,296	617	3,268	100	802,500	6,530
76,500	979	49,751	1,125	8,707	758	4,481	144	869,700	6,900
86,500	1,010	60,836	1,154	12,682	832	6,283	219	940,700	7,300
97,000	1,066	72,701	1,211	16,984	889	8,906	308	1,015,700	7,710
108,200	1,142	85,131	1,265	21,495	915	12,393	391	1,094,900	8,130
119,900	1,224	98,111	1,315	27,113	952	16,706	473	1,178,300	8,570
132,700	1,311	111,811	1,364			21,899	567	1,266,400	9,030
146,200	1,391	125,681	1,402			28,101	675	1,359,200	9,530
160,200	1,453	139,921	1,439			35,404	787	1,457,100	10,050
175,000	1,505	154,586	1,476			44,037	942	1,560,300	10,590
190,200	1,553	169,691	1,515			54,237	1,100	1,669,000	11,150
206,000	1,596	185,196	1,554			66,110	1,250	1,783,300	11,720
222,200	1,642	201,096	1,597			79,744	1,480	1,903,600	12,330
238,900	1,690	217,371	1,640			95,337	1,640	2,030,000	12,960
256,090	1,740	234,076	1,682			113,313	1,960		
273,700	1,792	251,231	1,721			134,591	2,300		
291,840	1,835	268,811	1,765			158,731	2,530		
310,380	1,873	277,879	1,792			184,827	2,690		
329,300	1,911					212,870	2,920		
348,600	1,949					242,866	3,080		
360,360	1,972					274,760	3,300		

Value may exceed modeled maximum storage for interpolaton purposes.

4.2.1.2 Bay Area Reservoirs

A physical relationship also exists between each of the Bay Area reservoir's storage and surface area. The surface area-storage relationship for each reservoir is defined by a series of paired storage values and area equations. The model determines the area for a computed reservoir storage using the area equations. The computed reservoir area is used by the model to estimate net evaporation for each month of the simulation.

The modeled operation of each of the Bay Area reservoirs considers a monthly preferred storage level. This storage level serves as a trigger to initiate modeled actions regarding the transference of water between reservoirs, drafting of local inflow or stored water through treatment facilities, or the release of water for flood control purposes. The storage level for each reservoir does not serve as absolute targets which drive reservoir operations. Rather, the value serves as a trigger to initiate water movement among the Bay Area reservoirs and into the distribution system. As a result of the water movement decisions, reservoir storage may ultimately be higher or lower than the preferred storage level. The preferred storage levels for Bay Area reservoirs are shown in Table 4.2.1.2-1. These values are representative of a system configuration and operation with Calaveras Reservoir being fully operable prior to the DSOD operational constraint.

**Table 4.2.1.2-1
Bay Area Reservoir Modeled Preferred Storage Levels (end-of-month)**

Month	Reservoir Storage - mg				
	Calaveras [1]	San Antonio	Crystal Springs [2]	San Andreas	Pilarictos
July	31,500	16,500	19,000	6,200	970
August	31,500	16,500	18,000	6,200	970
September	30,000	15,900	17,000	5,600	890
October	28,500	15,900	17,000	5,600	810
November	27,000	15,900	17,000	5,600	720
December	27,000	15,900	17,000	5,600	720
January	28,500	15,900	17,000	5,600	720
February	30,000	15,900	17,000	5,600	900
March	31,500	16,500	17,000	5,600	970
April	31,500	16,500	19,000	6,200	970
May	31,500	16,500	19,000	6,200	970
June	31,500	16,500	19,000	6,200	970

[1] As designed and constructed.

[2] Since 1983, the DSOD has placed operational restrictions on Lower Crystal Springs Dam

Winter storage levels were based on SFPUC historical operation experience and iterative analysis that attempted to maximize the utilization of local watershed runoff, minimize spill and maximize May 1 storage within the Bay Area system for drought protection. The analysis was based on the historical record of hydrologic variance. Various modeled system actions occur at various levels for each reservoir.

The operation of the local system is generally driven by local inflow in a month and the monthly preferred storage levels. For the purpose of planning studies, the model assumes perfect knowledge of reservoir inflows for the current month. Diversions from the Tuolumne River are used to minimize Bay Area storage fluctuations during drought, i.e., maintain preferred Bay Area storage for reserves.

4.2.2 Pipelines and Conveyance Facilities

HH/LSM performs the system simulation with a monthly time step, with water balances typically occurring in terms of monthly volumes of water. However, the model adheres to several overarching capacity constraints that occur hydraulically within the system. Salient capacity constraints incorporated into HH/LSM are described below.

Water is conveyed through the Hetch Hetchy and Bay Area systems via a series of tunnels and pipelines. From Hetch Hetchy Reservoir, water is conveyed through the Canyon Power Tunnel up to a rate that is dependent upon the head developed at Hetch Hetchy Reservoir, with a maximum rate approximately 1,400 cfs. Mountain Tunnel can convey approximately 660 cfs (currently constrained) and any flow through Canyon Power Tunnel in excess of this rate is modeled to be released back to the Tuolumne River at Early Intake. The Foothill Tunnel, which originates at Moccasin Reservoir and connects to the San Joaquin Pipelines is not capacity constrained in HH/LSM. This segment of conveyance is connected to the San Joaquin Pipelines which were designed to have a combined capacity of approximately 465 cfs (300 mgd). Cherry Power Tunnel is modeled to convey water up to a flow rate of approximately 970 cfs.

The San Joaquin Pipelines are currently a bottleneck in San Francisco's conveyance capacity between the Tuolumne River and the Bay Area systems. HH/LSM models the SJPL to operate at several levels of flow, which are dependent on assumptions for the number of pipes in service and valve settings. Under the current configuration of the system, the model assumes 11 discrete flow rates, ranging from a minimum of 70 mgd to a maximum of 290 mgd. Up to 19 discrete flow rate settings have been incorporated into HH/LSM, with seasonal over-riding capacity limits capable of being identified (for purposes of mimicking maintenance outages).

The Coast Range Tunnel is not capacity constrained in the model. Between the Alameda East Portal and the Alameda West Portal, several facilities manage waters from Hetch Hetchy with waters from the San

Antonio and Calaveras reservoirs. At times water can be imported to San Antonio Reservoir from either Hetch Hetchy or Calaveras Reservoir. The model limits pumping to San Antonio Reservoir from Calaveras Reservoir to 60 mgd, and from Hetch Hetchy to 125 mgd. Water can be released from Calaveras Reservoir to Sunol Valley WTP up to a rate of 90 mgd. Water can be released from San Antonio to Sunol Valley WTP up to a rate of 140 mgd if pumping at San Antonio Pump Station is provided.

HH/LSM does not incorporate the Irvington Tunnel as a capacity constrained facility with the current configuration of the Bay Division Pipelines. The pipelines are modeled to constrain the conveyance of water from the East Bay system to the South Bay and Peninsula areas. Seasonal capacity limits are provided to the model. For the current configuration of the system, maximum capacity into the pipelines is assumed to be 340 mgd June through September, 320 mgd April, May and October, and 290 mgd November through March. Maintenance can be modeled with seasonal over-riding capacity limits.

Pumping of water from Crystal Springs Reservoir into San Andreas Reservoir through the Crystal Springs Pump Station is model constrained between 75-90 mgd, dependent on the calculated head differential between the two reservoirs. Modeled conveyance of water from Pilarictos Creek to the San Mateo system is capacity constrained to no more than 40 mgd from Pilarictos Reservoir and another 40 mgd from Stone Dam.

4.2.3 Power Facilities

Hetch Hetchy facilities provide incidental power generation. Water released from Lake Lloyd and Lake Eleanor (via the Cherry-Eleanor Tunnel) primarily flows through Holm Powerhouse. A significant portion of the water released from Hetch Hetchy Reservoir flows through Kirkwood Powerhouse and subsequently through Moccasin Powerhouse. A small amount of water flows through the Moccasin Low Head Powerhouse to Moccasin Creek. Hydroelectric generation is modeled in HH/LSM from Holm Powerhouse (two units up to approximately 167 MW total), Kirkwood Powerhouse (three units up to approximately 115 MW total), and Moccasin Powerhouse (two units up to approximately 110 MW total). Modeled generation at the facilities considers flow rate and head calculated by the model. The Moccasin Low Head Powerhouse is not modeled in HH/LSM, and there are currently no hydroelectric generation facilities in the Bay Area system.

4.2.4 Treatment Facilities

The Sunol Valley WTP is used primarily to filter water from the East Bay reservoirs, although it can incorporate water from Hetch Hetchy. The model has the functionality to incorporate water into Sunol Valley WTP released from Calaveras Reservoir, San Antonio Reservoir, Hetch Hetchy, and water released from Calaveras Reservoir and recaptured from Alameda Creek. The sustainable capacity of the plant is 160 mgd. The plant is operated on an ongoing basis at a minimal level of about 20 MGD because treatment problems are more likely to occur when plants initiate operations or ramp up quickly in rate. HH/LSM allows input of a seasonal (monthly) maximum rate of treatment capacity and a minimum required treatment capacity for the plant. For the current configuration, HH/LSM constrains the plant to a maximum of 120 mgd of treatment capacity during a month, and a minimum production of no less than 20 mgd during a month.

The Harry Tracy WTP filters water from San Andreas Reservoir. Identical to the Sunol Valley WTP, HH/LSM constrains the modeled range of operation for the plant. The maximum production rate of the plant is 160 mgd, with a sustainable capacity of 140 mgd if turbidity is less than 5 NTU and 120 mgd when turbidity is greater than 5 NTU. HH/LSM allows input of a seasonal (monthly) maximum rate of treatment capacity and a minimum required treatment capacity for the plant. For the current configuration, HH/LSM constrains the plant to a maximum of 120 mgd of treatment capacity during a month, and a minimum production of no less than 20 mgd during month.

4.3 Operations

A summary of the general procedures and parameters used by HH/LSM in modeling the SFPUC Regional Water System follows.

4.3.1 Tuolumne System Operations

HH/LSM integrates the operation of the SFPUC's three major Tuolumne River reservoirs, Hetch Hetchy Reservoir, Lake Lloyd, and Lake Eleanor with the operation of the Don Pedro Water Bank Account, and is responsive to the modeled need for water from the Bay Area system. In general each reservoir is a balancing mechanism for watershed inflows, minimum release requirements, and releases for water demands. Incidentally and opportunistically, hydroelectric generation also occurs. The Don Pedro Project is also modeled by HH/LSM.

4.3.1.1 Hetch Hetchy Reservoir

Hetch Hetchy Reservoir is modeled to regulate the reservoir's watershed runoff with minimum stream releases, releases to Canyon Tunnel, and releases below the reservoir which are in excess of minimum requirements.

As described later, minimum stream releases below Hetch Hetchy Reservoir are determined by precipitation and runoff indicators, and are also dependent upon the operation of Canyon Tunnel. These releases become an absolute obligation of the reservoir. Diversions to Canyon Tunnel are dependent first upon the call for water from the Bay Area system (described below in Section 4.3.1.4, San Joaquin Pipelines). Diversions to San Francisco from Hetch Hetchy for domestic use normally originate from Hetch Hetchy Reservoir. Additional diversions to Canyon Tunnel may occur for an enhanced power operation if appropriate hydrologic conditions occur (described below in Section 4.3.1.6, Hetch Hetchy Power Operations).

In anticipation of snowmelt runoff, HH/LSM will model Hetch Hetchy Reservoir being lowered by releases through Canyon Tunnel. This reduction in storage normally begins in early winter as the model's forecast of snowmelt runoff indicates anticipated spill around SFPUC powerhouses. Drawdown of reservoir storage is limited first by releases necessary for diversion to the Bay Area system and minimum downstream flow requirements, and secondly by the capacity of Kirkwood Powerhouse. The primary objective of Hetch Hetchy Reservoir's operation is to develop maximum reservoir carryover storage into the summer season, and maintain reservoir storage for as long as possible.

After the snowmelt season, Hetch Hetchy Reservoir storage levels will begin to decline as water diversions to the Bay Area system increase and inflow subsides. In circumstances when inflow to Hetch Hetchy Reservoir and water demands of the SFPUC are such that Hetch Hetchy Reservoir remains essentially full into the fall (a rare event following an extremely wet year), the model will lower reservoir storage by November 1, to provide the buffer reservoir space below the spillway sill. This additional release is made through Canyon Tunnel and ultimately spills from Moccasin Reservoir.

4.3.1.2 Lake Lloyd and Lake Eleanor

Similar to the Hetch Hetchy Reservoir operation, the Lake Lloyd and Lake Eleanor system is also modeled to conserve reservoir inflow for both water supply and hydroelectric generation. Winter and spring operations rely on the occurrence and forecast of runoff which at times allows drawdown of reservoir storage. This drawdown of storage allows greater utilization of Holm Powerhouse. Water transfer capability from Lake Eleanor to Lake Lloyd through the Eleanor-Cherry Tunnel and Pumping Plant allows the utilization of runoff from the Eleanor Creek watershed through Holm Powerhouse; thus, the operation of the two watersheds is integrally linked. Like Hetch Hetchy Reservoir, maximum carry-over storage into the summer-time season (which is potentially the beginning of an extended drought) is the primary objective for modeled reservoir operations.

Minimum stream releases from Lake Lloyd and Lake Eleanor are determined by criteria described in Section 4.4. Lake Lloyd minimum stream releases are the same every year, while Lake Eleanor minimum stream releases depend upon the use or non-use of the Cherry-Eleanor Pump Station for transference of water between the two reservoirs. Releases to the streams in excess of minimum requirements below the impoundments are modeled only when there is no reservoir space available to regulate inflow and conveyance or generation capacity is modeled at maximum. Releases through Holm Powerhouse are governed by the model's attempt to avoid spills to the stream below Lake Lloyd and Lake Eleanor. After the snowmelt season, diversions to Holm Powerhouse are determined by the releases needed to draw Lake Lloyd down to the preferred storage level indicated for each month. These releases are comprised of the evacuated storage and the inflow to the reservoir from its watershed and from Lake Eleanor not released for minimum stream flows. The Lake Lloyd summer-time drawdown associated with the preferred storage levels along with the diversion of an amount of the reservoir's inflow coincidentally provides for desired recreational flows downstream of Holm Powerhouse.

Transference of water from Lake Eleanor to Lake Lloyd occurs when, in consideration of the preferred storage levels at Lake Eleanor, releases in excess of minimum stream flow requirements occur or are forecasted to occur below Lake Eleanor. The model determines if this transference occurs as gravity flow or if it requires pumping, based on the reservoir condition of both reservoirs.

The Water Bank Account in Don Pedro Reservoir will typically not vary from full significantly during many years. However, during periods of drought the Water Bank Account will be significantly debited as the model's reservoir operation logic attempts to retain storage in SFPUC upstream reservoirs. In order to maintain a positive balance in the Water Bank Account, the model has the functionality to call for releases from both Hetch Hetchy Reservoir and Lake Lloyd. The amount of water released from each reservoir is defined by model input that indicates the percentage desired from each of the reservoirs and constraints for the release based on each reservoir's storage. The Lake Lloyd and Lake Eleanor system is typically used to provide releases to the Districts.

4.3.1.3 Water Bank Account

The operation of San Francisco's Water Bank Account in Don Pedro Reservoir is normally incidental to San Francisco's upstream operations. With the objective to maintain as much water as possible within the reservoirs and account of the SFPUC, under normal circumstances the balance of the Water Bank Account will vary up and down within a year. Significant drawdown of the Water Bank Account occurs early during drought as runoff is held in upstream SFPUC reservoirs. Within a year, the balance will vary as San Francisco uses available space in the Water Bank Account to enhance power operations. The Water Bank Account balance is not allowed to be less than zero in HH/LSM; however, logic has been incorporated into HH/LSM to provide transfers of water into the Water Bank Account.

The Districts' Raker Act entitlements and Fourth Agreement rights to inflow to Don Pedro Reservoir are required for the determination of the balance of the Water Bank Account. A monthly time series for these values has been determined from an analysis of historical daily runoff of the Tuolumne River. For modeling purposes, the values are used in the comparison of regulated inflow to Don Pedro Reservoir to the unimpaired flow of the Tuolumne River to determine the change in Water Bank Account balance.

4.3.1.4 San Joaquin Pipelines

The operation of the San Joaquin Pipelines is primarily dependent on the supplemental needs of San Francisco's Bay Area system operations to meet water demands. The seasonal level of the San Joaquin Pipelines diversion is consistent with one of the combinations of pipeline operation configurations described previously. Maintenance to the pipelines is modeled as an over-riding seasonal capacity limit. Also, maintenance is modeled to occur annually and on less than annual cycles. Additionally, month to month changes to the flow in the pipelines are constrained.

For each month, HH/LSM determines the need for supplemental water from Hetch Hetchy. This need is determined by the simulated operation of the Bay Area system. The need for Hetch Hetchy water is the

residual amount of demand from the Bay Area system after all of the Bay Area system-alone operational protocols have been applied. These protocols include the consideration of the Bay Area reservoir preferred storage levels, water demands, and conveyance and treatment plant capacities. The residual need from Hetch Hetchy incorporates the system water demand net of the amount of water needed for the consideration of the preferred storage levels.

The identified need for Hetch Hetchy water through the pipelines mathematically can be any value. However, HH/LSM embodies practicable operational considerations that require the flow rate to match a flow that can exist with established valve settings and pipeline configurations. The model also considers the previous month's pipeline flow rate and further constrains the number of times the flow rate can change during a year. After this conditioning of the flow rate there is typically a difference between the originally established need for Hetch Hetchy water and the pipeline flow rate. A positive difference (more water transferred than requested) is balanced within the Bay Area system by storing water, and a negative difference (less water transferred than requested) is balanced by depleting the Bay Area reservoirs. Although the San Joaquin Pipelines are defined to have a minimum rate of operation (the current configuration assumes 70 mgd), HH/LSM over-rides this constraint and minimizes flow from Hetch Hetchy during periods when the Bay Area system is modeled to be in an extreme spill condition.

4.3.1.5 Lower Cherry Aqueduct

HH/LSM has functionality to simulate the use of the Lower Cherry Aqueduct (LCA) to transfer water from the Cherry-Eleanor watersheds to Early Intake for transport to the Bay Area system. The model can trigger the use of the LCA in two different conditions: one reacting to drought conditions, which triggers on specified reservoir storage levels at Lake Lloyd and Hetch Hetchy Reservoir, and the other triggering an increased conservation of runoff from the Cherry-Eleanor watersheds during times when Hetch Hetchy Reservoir has available reservoir space. Under the current configuration setting the modeled use of the LCA is not occurring.

4.3.1.6 Hetch Hetchy Power Operations

HH/LSM can model reservoir operations to maximize water supply at the risk of less than optimal operations for other purposes such as power generation. The most conservative water supply operation suggests holding water in storage until spilled. However, there are circumstances that warrant early additional releases from reservoirs in anticipation of releases that otherwise could result in spills around San Francisco's hydroelectric facilities.

The model forecasts anticipated runoff to the San Francisco Tuolumne River reservoirs using a forecasting procedure that is nearly identical to the procedure used by system operators. Based on a database of historical snow course and watershed runoff information, a statistically-based procedure has been developed that provides a temporal runoff forecast for each basin which is dependent upon the modeler's desire for confidence in the forecast. By increasing the risk factor associated with the forecast the operation of the reservoirs can become less conservative and thus increase hydroelectric generation. The resultant reservoir operation involves the early release (when available hydroelectric generation capability exists) of reservoir inflow and storage before such time that the hydroelectric facilities operate at maximum and releases must bypass the facilities.

The forecasting routine projects the amount of runoff that can be expected to occur to each San Francisco reservoir, Don Pedro Reservoir and the Water Bank Account. The amount of certainty concerning precipitation yet to come and procedural error assumed in the forecast is prescribed by the modeler. Once the amount of anticipated runoff is projected, the runoff is compared to the availability of reservoir storage to capture the runoff and the anticipated releases required from the reservoir for downstream requirements and diversions to San Francisco. If the reservoir is projected to spill during the month or in aggregate by July 1, discretionary releases (up to the amount of anticipated spill) are allowed in order to enhance power generation from the project. This forecasting and decision process occurs continuously each month of the period being modeled.

The currently used criteria for the anticipatory release of water for power generation enhancement have been established through iterative refinement of the long-term HH/LSM studies. In order to not affect the amount of water delivered resulting from the most conservative water supply analysis, it has been determined that seasonal operations based on risk assumption should not be modified for power enhancement during the months of July through November, i.e., Hetch Hetchy should be operated in a conservative mode. However, during December through June the forecast can be “relaxed.” This relaxation equates to increasing the forecast risk from 99 percent exceedence (during the July through November period) to 98 percent in December, 90 percent in January and February, 75 percent in March, and 50 percent during April through June. These factors are adjustable within the input to HH/LSM.

4.3.1.7 Don Pedro Project

HH/LSM models the operation of the Don Pedro Project. Don Pedro Reservoir is modeled to regulate inflow with the requirements for stream flow below La Grange Dam, diversions to the Districts' canals, and flood control. Canal diversions are determined by a procedure that is based on the assumed consumptive use needs of the Districts and a water balance for the diversion canals, regulating reservoirs and other supply resources of the Districts in their service areas. Flow requirements below La Grange, as specified by the Federal Energy Regulatory Commission (FERC) license, are met with releases from Don Pedro Reservoir, and flood control reservation space in Don Pedro Reservoir cannot be encroached. If designated in HH/LSM, Don Pedro Reservoir will only release water necessary to satisfy minimum stream flows below La Grange Dam, canal diversions, or to maintain required flood control reservation space. HH/LSM contains logic to provide early releases in excess of minimum stream requirements in order to reduce spill past the powerhouse during seasons of high inflow and constrained storage.

The following describes the modeling of operations of the Don Pedro Project with respect to serving the demand of the Districts and meeting downstream minimum release requirements. Minimum release requirements below La Grange, as specified by the Don Pedro FERC license, are additionally described in Section 4.4.

The methodology used to determine the diversion requirement for the Districts uses a water budget approach. The water budget develops a canal diversion demand based upon estimates of the consumptive use of applied water (CUAW), non-recoverable losses and inferred deep percolation, District and private groundwater pumping, system losses, operational spills, and regulating reservoir operation. The CUAW numbers are generated by the Department of Water Resources-United States Bureau of Reclamation consumptive use model which estimates the CUAW based on precipitation, crop ET and crop acreage. These monthly data were generated for the simulation period. MID's diversion demand includes municipal use drawn from Modesto Lake.

Don Pedro Reservoir is modeled to not exceed a pre-defined maximum allowable end-of-month storage. These values represent the historic or simulated flood control storage limit provided by the Corps of Engineers. Table 4.3.1.7-1 depicts the monthly values for this maximum storage. Although there is not a required reservation of space during the summer, HH/LSM has the functionality to provide a preferred storage level for each month which serves as an over-ride to values shown in the table. This capability provides a surrogate method to make stream releases in excess of minimum stream requirements, which will draw Don Pedro Reservoir down to flood control levels systematically during wetter years when substantial releases in the early fall would otherwise occur.

HH/LSM also incorporates procedures that evaluate the condition of Don Pedro Reservoir storage in the context of diversions to the Districts' canals. A water supply index is determined each year based on projected spring-time storage in Don Pedro Reservoir. If drought is occurring the model will reduce the demand being served by the Districts to prolong the availability of storage in the reservoir. A demand served–water supply index relationship has been developed based on iterative analysis of District operation simulations. This relationship currently provides for the demand being served to range between 50 percent and 100 percent. The lower end of the range usually occurs only within sequences of dry years. Most model parameters affecting the Districts' operation of their canal systems can be modified through user-defined input.

4.3.2 Bay Area System Operations

The Bay Area system provides regulation between water demands, local watershed runoff and imported water from Hetch Hetchy. The primary objectives of the system are to conserve local watershed runoff for delivery, and to satisfy system water demands. Modeling of the Bay Area system involves many pieces of logic (algorithms) that make decisions concerning how water demands are met and how water in the system is routed and balanced between the reservoirs. The decisions are made sequentially, with the results sometimes conflicting with a later recognized constraint. An earlier decision is at times revisited by the model, or subsequent decisions occur to remedy the conflict. The following provides a summary of the flow of algorithms that has been developed to simulate the operation of the Bay Area system.

4.3.2.1 Water Demands and Deliveries

As described earlier, HH/LSM is provided a water demand (purchase request) to satisfy. This annual average annual demand is disaggregated into the demand centers in terms of volume and monthly distribution. The volume and shape of the demand is also identified for pre-established levels of delivery shortages. During the April time step of each year the model forecasts the total reservoir storage of the system for the end of June and initially establishes the level of water delivery shortage or water supply action necessary for the current year. This information is updated during the July time step, with the resulting action applied to operations for the July through following June time period.

4.3.2.2 Pilarcitos Reservoir and Coastside CWD

The modeled objective of Pilarcitos Reservoir operation is the conservation of runoff for 1) Coastside CWD deliveries, and 2) transference to the remainder of the SFPUC system. Consistent with the ending of the rainy season, the model attempts to fill the reservoir (and all of the Bay Area system reservoirs) by the end of April. Releases from the reservoir to Pilarcitos Creek only occur to the extent that accretion flow below the dam does not satisfy Coastside CWD demand, unless the reservoir is full (or at its preferred storage level) and the transference of water to San Andreas Reservoir is already maximized. Water in excess of Coastside CWD needs will be released for 1) transference to Crystal Springs Reservoir (at Stone Dam) and 2) spill past Stone Dam. San Andreas and Crystal Springs reservoirs may reject transferees from the Pilarcitos system if their storage condition warrants. After filling, Pilarcitos Reservoir is drawn down by the need to satisfy the portion of Coastside CWD's demand not met from accretion flow occurring between Pilarcitos Dam and Stone Dam. HH/LSM allows the draw from Pilarcitos Reservoir to occur until a specified storage is reached (typically the invert elevation of the outlet works). At that time any Coastside CWD delivery not met at Stone Dam is drawn from Crystal Springs Reservoir.

4.3.2.3 San Andreas Reservoir and Crystal Springs Reservoir

The Crystal Springs Reservoir operation and San Andreas Reservoir operation is very intertwined. Both reservoirs are modeled to be drawn down in the fall and maintained at preferred reservoir levels during winter, either by demands exceeding inflows, or by explicit evacuation of storage by additional production at Harry Tracy WTP. The maintenance of available reservoir storage space facilitates the conservation of watershed runoff during the winter and spring. Part of this reservoir operation occurs through explicit use of Harry Tracy WTP draft from San Andreas Reservoir. If storage at Crystal Springs Reservoir exceeds preferred storage levels, water is transferred to San Andreas Reservoir by the Crystal Springs Pumping Plant. This transference may contribute to or cause San Andreas Reservoir storage to exceed its preferred storage level. Production at Harry Tracy WTP attempts to deliver the volume in excess of the preferred storage level, but is limited by the amount of system water demand potentially met with its production. If the Crystal Springs Reservoir transference to San Andreas Reservoir causes San Andreas Reservoir storage, after draft to Harry Tracy WTP, to be greater than the preferred storage level, the Crystal Springs Reservoir transference will be reduced so as not cause the conflict. If Crystal Springs Reservoir exceeds its preferred storage level, plus a user-specified allowance, releases up to 250 cfs will be made from Crystal Springs Dam to San Mateo Creek.

When the storage at San Andreas Reservoir is less than its preferred storage level, transfers from Crystal Springs Reservoir to San Andreas Reservoir will occur to achieve the preferred storage level. Similarly, the model uses the transfer of water from the East Bay system (including Hetch Hetchy supplies) to achieve the preferred storage level in Crystal Springs Reservoir.

4.3.2.4 San Antonio Reservoir and Calaveras Reservoir

The San Antonio Reservoir operation and Calaveras Reservoir operation are dependent upon operation goals to conserve their watersheds' runoff, and also upon the operational priority given to the Peninsula system operation.

Similar to the operation described for the Peninsula reservoirs, San Antonio and Calaveras reservoirs' fall and winter operation is guided by preferred storage levels that provide reservoir space to regulate rainfall runoff. Sunol Valley WTP is utilized to maintain preferred storage levels in the reservoirs. The amount of water that can be drafted to Sunol Valley WTP can at times be constrained by system water deliveries and the need to draft water from the Peninsula reservoirs. During those constrained instances, flows to the Peninsula will be rejected. In instances when Calaveras Reservoir exceeds its preferred storage level and Sunol Valley WTP is constrained, the model will transfer Calaveras Reservoir water to San Antonio Reservoir if reservoir space is available in the reservoir. Spills will be modeled from the reservoirs when inflow exceeds reservoir storage availability and draft to Sunol Valley WTP.

Calaveras Reservoir operations also affect the operation of Alameda Creek diversions at the Alameda Creek Diversion Dam. HH/LSM provides a diversion of flow at the diversion dam to Calaveras Reservoir whenever Calaveras Reservoir is below its preferred storage level. Water not diverted to Calaveras Reservoir continues past the diversion dam and contributes to flow that reaches the Alameda Creek and Calaveras Creek confluence.

HH/LSM has the functionality to model a minimum release requirement at the Calaveras Creek and Alameda Creek confluence. The logic is consistent with the principals specified by the Memorandum of Understanding (MOU) between the SFPUC and the California Department of Fish and Game. The MOU specifies minimum flow requirements in Alameda Creek at the confluence with Calaveras Creek. The stream flow requirement is met through releases at Calaveras Dam as needed to supplement unregulated flows that occur at the confluence. In the HH/LSM model, these supplemental releases are assumed to be recaptured by a downstream facility and transferred into the water supply system at Sunol Valley WTP.

4.4 Minimum Stream Release Requirements

4.4.1 Hetch Hetchy Reservoir

Fishery releases to the Tuolumne River below O'Shaughnessy Dam are governed by several stipulated agreements between San Francisco and the Department of Interior. The regime of release is defined within three year-type classifications, coined as year types A, B & C. The classification of a year is dependent on the occurrence of precipitation and runoff at Hetch Hetchy Reservoir. Table 4.4.1-1 set forth the criteria that determine the year type classification and required monthly releases to the Tuolumne River below O'Shaughnessy Dam.

In addition to the basic release schedules shown in Table 4.4.1-1, the U.S. Fish and Wildlife Service has discretion to require supplemental releases of additional water from Hetch Hetchy Reservoir. These releases amount to 15,000, 6,500 and 4,400 acre-feet during year types A, B and C, respectively. Also, during year types A and B, an additional 64 cubic feet per second release below Hetch Hetchy Reservoir can be required whenever Canyon Tunnel flow exceeds 920 cubic feet per second. The release of 4,400 acre-feet during a year type C can be required only if Hetch Hetchy Reservoir storage is greater than 210,000 acre-feet on July 1 of that year.

Releases to the Tuolumne River below O'Shaughnessy Dam as applied in the model are summarized in Table 4.4.1-2.

**Table 4.4.1-1
Average Daily Required Fishery Release Schedule Below O’Shaughnessy Dam**

Month	Year Type A		Year Type B		Year Type C
	Release (cfs)	Criteria ^{a,b}	Release (cfs)	Criteria ^{a,b}	Release (cfs)
January	50	8.80"	40	6.10"	35
February	60	14.00"	50	9.50"	35
March	60	18.60"	50	14.20"	35
April	75	23.00"	65	18.00"	35
May	100	26.60"	80	19.50"	50
June	125	28.45"	110	21.25"	75
July	125	575,000 acre-feet	110	390,000 acre-feet	75
August	125	640,000 acre-feet	110	400,000 acre-feet	75
September 1-14	100		80		75
September 15-30	80		65		50
October	60		50		35
November	60		50		35
December	50		40		35

^a Precipitation indicator in inches is cumulative, measured at Hetch Hetchy Reservoir, starting October 1.

^b Runoff indicator in acre-feet is the calculated inflow into Hetch Hetchy Reservoir commencing on the previous October 1.

**Table 4.4.1-2
Modeled Monthly Minimum Release Below O’Shaughnessy Dam – Acre-feet**

Month	Type A			Type B			Type C		
	F&W Release	Discretionary Release	Total Release	F&W Release	Discretionary Release	Total Release	F&W Release	Discretionary Release ^a	Total Release
October	3,689	0	3,689	3,074	0	3,074	2,152	0	2,152
November	3,570	0	3,570	2,975	0	2,975	2,083	0	2,083
December	3,074	0	3,074	2,460	0	2,460	2,152	0	2,152
January	3,074	0	3,074	2,460	0	2,460	2,152	0	2,152
February	3,362	0	3,362	2,802	0	2,802	1,961	0	1,961
March	3,689	0	3,689	3,074	0	3,074	2,152	0	2,152
April	4,463	0	4,463	3,868	0	3,868	2,083	0	2,083
May	6,149	0	6,149	4,919	0	4,919	3,074	0	3,074
June	7,438	0	7,438	6,545	0	6,545	4,463	0	4,463
July	7,686	6,000	13,686	6,764	2,600	9,364	4,612	1,800	6,412
August	7,686	6,000	13,686	6,764	2,500	9,264	4,612	1,800	6,412
September	5,316	3,000	8,316	4,284	1,400	5,684	3,669	800	4,469
Total	59,196	15,000	74,196	49,989	6,500	56,489	35,165	4,400	39,565

^a If July first-of-month storage at Hetch Hetchy Reservoir is less than 210,000 acre-feet program will not make the discretionary release.

4.4.2 Lake Lloyd and Lake Eleanor

Fishery releases below Lake Lloyd to Cherry Creek are maintained in all years. Table 4.4.2-1 describes these releases that vary monthly between 5 cubic feet per second and 15.5 cubic feet per second. Releases below Lake Lloyd as applied in the model are also summarized in Table 4.4.2-1.

**Table 4.4.2-1
Modeled Monthly Minimum Release Below Lake Lloyd**

Month	Release to Stream	
	(cfs)	(acre-feet)
October	5	307
November	5	298
December	5	307
January	5	307
February	5	278
March	5	307
April	5	298
May	5	307
June	5	298
July	15.5	953
August	15.5	953
September	15.5	922
Total		5,535

Fishery releases below Lake Eleanor to Eleanor Creek are dependent on the operation of the Eleanor-Cherry Diversion Tunnel. Table 4.4.2-2 depicts the releases made to Eleanor Creek under both a pumping mode and gravity flow mode. Releases below Lake Eleanor as applied in the model are also summarized in Table 4.4.2-2.

**Table 4.4.2-2
Modeled Monthly Minimum Release Below Lake Eleanor**

Month	With Pumping ^a		Gravity Flow Without Pumping ^a	
	(cfs)	(acre-feet)	(cfs)	(acre-feet)
October	10	615	5	307
November	5	298	5	298
December	5	307	5	307
January	5	307	5	307
February	5	278	5	278
March	10	615	5	307
April 1-14	10	278	5	139
April 15-30	20	635	5	159
May	20	1,230	5	307
June	20	1,190	5	298
July	20	1,230	16	953
August	20	1,230	16	953
September 1-15	20	595	16	461
September 16-30	10	298	16	461
Total		9,106		5,535

^a The agreement for the operation of the Eleanor-Cherry Tunnel and Pumping Plant calls for different fishery release schedules below Eleanor Dam depending on whether or not the pumping plant is used.

4.4.3 Don Pedro Reservoir

Minimum flows for the Tuolumne River below La Grange Dam are required by the FERC license for the New Don Pedro Project. The FERC license identifies ten year-type classifications for the Tuolumne River, of which only seven have distinctly different minimum flow schedules. Table 4.4.3-1 illustrates the determination of the year-type classification as indexed to the State Water Resources Control Board San Joaquin Valley Water Year Hydrologic Classification.

**Table 4.4.3-1
Tuolumne River FERC Flow Requirement Year-Type Classification**

FERC Year Type Classification	San Joaquin Valley Hydrologic Classification 60-20-20 Index (1,000 AF)
Critical and Below	<1,500
Median Critical	1,500
Intermediate Critical / Dry	2,000
Median Dry	2,200
Intermediate Dry / Below Normal	2,400
Median Below Normal	2,700
Intermediate Below Normal / Above Normal	3,100
Median Above Normal	3,100
Intermediate Above Normal / Wet	3,100
Median Wet / Maximum	3,100

For each year-type classification, a basic schedule of flows is identified for the break point for the year type (Table 4.4.3-2). For example, if the San Joaquin Valley Hydrologic Classification index is 1,550 thousand acre-feet (TAF) the year is classified as Median Critical and its basic schedule is a volume of 103,000 AF. The FERC license requires an interpolation of schedules within year type classifications. Therefore, the annual FERC requirement for this example is a linearly interpolated volume between the Median Critical schedule (103,000 AF) and the Intermediate Critical / Dry schedule (117,016 AF). HH/LSM assumes the amount of water determined by the interpolation is added to the basic schedule during the out migration pulse flow period.

**Table 4.4.3-2
Tuolumne River FERC Flow Requirement Requirements**

Period	FERC Year Type Classification						
	Critical and Below	Median Critical	Intermed Critical / Dry	Median Dry	Intermed Dry / Below Normal	Median Below Normal	Intermed Below Normal / Above Normal and Above
Annual Volume (acre-feet)	94,000	103,000	117,016	127,507	142,502	165,002	300,923
October 1 – 15	100	100	150	150	180	200	300
Attraction Pulse Flow (acre-feet)	None	None	None	None	1,676	1,736	5,950
October 16 - May 31	150	150	150	150	180	175	300
Out migration Pulse Flow (acre-feet)	11,091	20,091	32,619	37,060	35,920	60,027	89,882
June 1 – September 30	50	50	50	75	75	75	250

Units: cfs unless otherwise noted.

4.4.4 Calaveras Reservoir

Minimum release requirements below Calaveras Reservoir are specified by the MOU between SFPUC and the California Department of Fish and Game. The MOU specifies minimum flow requirements in Alameda Creek at the confluence with Calaveras Creek. The stream flow requirement is met through releases at Calaveras Dam as needed to supplement unregulated flows that occur at the confluence. The total annual obligation is up to 6,300 acre-feet/year. The monthly flow requirements at the confluence as modeled by HH/LSM are presented in Table 4.4.4-1. These requirements are assumed not in effect while the Calaveras Dam is operating at a reduced capacity due to DSOD requirements.

**Table 4.4.4-1
Alameda Creek MOU Flow Requirement Requirements**

	Average Monthly (cfs)	Volume (acre-feet)
October	7	430
November	5	298
December	5	307
January	13	799
February	20	1121
March	13	799
April	7	417
May	7	430
June	7	417
July	7	430
August	7	430
September	7	417

4.4.5 San Antonio Reservoir

There are no minimum release requirements below San Antonio Reservoir.

4.4.6 Peninsula Reservoirs

There are no minimum release requirements below the Peninsula reservoirs.

5. Modifications to HH/LSM for WSIP Analyses

Several modifications were made to the model to evaluate projects and operations considered in the evaluation and development of the Water System Improvement Program (WSIP). These modifications enhanced the functionality of the model. The following provides a brief description of various water supply and management options that are additionally available for evaluation by the model.

5.1 Retail Customer Recycled Water/Groundwater/Conservation

The “City Gradient” water demands can be offset to incorporate an assumed level of water demand reduction attributed to implementation of recycled water, groundwater or conservation. The amount of offset is defined by month and is applied each year of the simulation.

5.2 Wholesale Customer Recycled Water/Groundwater/Conservation

Each of the wholesale customer “gradients” water demand can be offset to incorporate an assumed level of water demand reduction attributed to implementation of recycled water, groundwater or conservation. The amount of offset is defined by month and is applied each year of the simulation.

5.3 Westside Basin Conjunctive Use Program

The Westside Basin Conjunctive Use Program is modeled as a water demand modifier to the San Andreas and Crystal Springs water delivery gradients. The functionality of the program is defined by the storage capacity (volume) of the underground reservoir, the rate at which increased Regional Water System deliveries can “store” water, and the rate at which increased groundwater pumping by the participants can “extract” water. The extraction mode of the program is triggered when the drought response is at a level of 1 or greater. Replenishment occurs whenever the storage is less than maximum and extraction is not occurring.

5.4 Tuolumne River Water Transfer

A water transfer to the SFPUC from the Districts can occur via the Water Bank Account in Don Pedro Reservoir. The transfer can be defined by month for each year of the simulation. The assumed transfer modifies the SFPUC’s account balance and the system will subsequently react to the modified balance.

5.5 Regional Dry-year Desalination

Regional dry-year desalination is modeled as a supplemental stream of water entering the Regional Water System through Sunol Valley conveyance. The stream of water is defined as a rate of production for each month of the year. The project’s production can be triggered by drought response level.

5.6 Oceanside Desalination

The production rate of the Oceanside Desalination Project is defined for each month of a year and is utilized in all years when this feature is applied. The production offsets the water demand of the “City Gradient”.

5.7 Lower Tuolumne River Diversion

This feature shifts a portion of the SFPUC’s Tuolumne River diversion to the lower Tuolumne River below La Grange Dam. The feature also triggers additional stream releases from O’Shaughnessy Dam coincident with the diversion from the lower Tuolumne River. A rate of potential diversion from the lower Tuolumne River is defined for the project. Whenever the Bay Area system requires Tuolumne River diversions in excess of the available capacity of the San Joaquin Pipelines a supplemental release from Hetch Hetchy Reservoir occurs which then is bypassed through Don Pedro Reservoir and La Grange Dam for diversion by the SFPUC from the lower Tuolumne River.

5.8 Delta Diversion

A source of supply originating from the Sacramento-San Joaquin Delta can be defined by a monthly and yearly array. The stream of water can be entered into the Regional Water System at two different locations: 1) inflow to San Antonio Reservoir, and 2) supplementing flow into Sunol Valley conveyance.

6. Model Verification

The HH/LSM was originally developed in 1988 and has undergone a continuous process of improvement. The model was used in support of an application to amend the license for the Don Pedro Project, which was submitted to the Federal Energy Regulatory Commission (FERC) in 1993 and 1994. FERC approved the use and results of the model for purposes of the amendment.

6.1 Parsons/CH2MHill Review

The model was reviewed again in 2005, as part of the Water Supply Improvement Program Assessment conducted by Parsons/CH2MHill. The purpose of this review was to determine if:

- the model adequately represents the SFPUC system;
- the fundamental assumptions of the model are reasonable based on the available data;
- the model has been applied in an appropriate manner; and,
- the model results have been incorporated into the decision/planning process.

The model review was conducted by looking at each element of HH/LSM to see if the model input data, assumptions, operational criteria, and results were within the expected range of practice for this type of model application. The review included brief checks of input hydrology, system demands, reservoir target storage levels and capacities, transmission system flow capacities, general operations criteria, and simulation procedure logic. Model Fortran source was not reviewed as part of the evaluation.

6.1.1 Conclusions

The following conclusions regarding the model were presented in the Parsons/CH2MHill report:

- The review of model input hydrology, system demands, representation of system facilities, operating criteria, and procedural simulation logic indicates that the model representation of the existing SFPUC system is reasonable as applied to the general types of planning purposes for which the model is designed. The monthly time step limits the model's intended use for planning applications, and it is not designed for analyzing power generation or system operations that require a weekly, daily, or even hourly assessment.
- The comparison of HH/LSM results with historical operations for the period 1986 through 1995 shows that the model provides a reasonable simulation of system deliveries and reservoir storage values for the existing SFPUC regional water system.
- HH/LSM provides a valuable planning tool that the SFPUC can use to evaluate drought periods to establish system firm yield, levels of required rationing, water transfer needs, and reservoir storage requirements. It can also be used to assess benefits and impacts to SFPUC regional water system long-term delivery reliability based on different mixes of water supply sources, levels of conservation, operations criteria, new transmission and storage facilities, and changing hydrologic conditions such as global climate warming.
- The SFPUC's drought planning methodology using HH/LSM provides a logical, defensible, and repeatable analytical process that can be used to develop yearly sequences of simulated design drought operations of SFPUC facilities to meet operational and delivery targets.
- The computer simulation of the SFPUC regional water system requires a fairly high level model code to allow adequate representation of the large number of transmission and storage facilities, regulatory requirements, and operational complexities of the system. The proper application of the model and interpretation of model results requires a person with a high level understanding of system operations and of HH/LSM to effectively apply the model and provide meaningful interpretation of model results.

6.1.2 Recommendations

The following recommendations regarding the model were presented in the Parsons/CH2MHill report:

- Develop consistent standards and protocols for HH/LSM analyses of WSIP projects and water supply options to allow proper model application, ensure comparable simulation results, and facilitate consistent sizing of new transmission and storage facilities (i.e., specification of maintenance windows and specific definitions of proposed future facilities).
- Conduct an HH/LSM workshop with WSIP staff to improve understanding of the capabilities and limitations of the model and allow for more effective assessment of how to incorporate the application of the model into projects at the planning, feasibility, and design levels.
- Improve coordination with analyses conducted with the hydraulic transmission system model by developing a procedure for iterating between the models to evaluate system operations, sizing of future facilities, and impacts on design drought operations and system yield. In some cases, it appears there may be inconsistencies between the assumptions in HH/LSM and the transmission model with regard to demands, conveyance capacities, and operational/maintenance strategies .
- The LOTUS preprocessor spreadsheets are outdated, and development of a new user interface should be considered to make model application more efficient and reduce potential data input errors.

6.2 Comparison of Model Results with Current Operations

It is the policy of the SFPUC to operate its water system in a prudent manner that maximizes the reliability and quality of water deliveries. These operations are grounded on numerous specific requirements described in several legal agreements, authorizing legislation, and regulatory requirements. Operations are also guided by judgment, strategies and historical experience. In total, formal and informal “rules” combine into the current operation of San Francisco’s Regional Water System. The operation of the San Francisco Regional Water System is a matter of historical record, an operation evidenced with an evolution that has been caused by natural events, changes in facilities and regulatory constraints, and changes in planning perspective and objectives. Because of this historically changing operation and physical regime, the historical record of operations does not depict a consistent operational philosophy. Also, due to the dynamic nature of actual operating conditions, including facility maintenance that affects short-term operations, and the limited hydrologic period that incorporates current operation objectives, the recent historical record of operations cannot fully describe system operation. Conclusions drawn from the review of the historical record must recognize and consider these changes and special circumstances.

Monthly water planning simulation models such as HH/LSM are difficult to validate against historical operations since these systems are complex and there are multiple variables associated with system facilities, operational strategies, and demands that affect year-to-year operations. Historical operations of the Hetch Hetchy and Bay Area facilities in earlier years of the system are a reflection of operating needs at that time. Since then, regulatory requirements, available system transmission and storage facilities, sources of supply, and demand levels have all changed. Therefore, simulation results for current system facilities, operating conditions, and 265 mgd of demand are not expected to validate against earlier years from the historical record. Historical data from more recent years with existing facilities in place and similar demand levels can be expected to more closely correlate with current model results. Simulated results for system deliveries, local reservoir storages, Hetch Hetchy upstream reservoirs, Don Pedro Water Bank Account, and Sunol Valley WTP operations track reasonably well with historic data over the most recent period, providing confidence in model performance. Overall, the simulation capabilities of the model appear to be appropriate for water supply planning based on the review of model input data, operating rules, simulation results, and available comparisons with historical operations data.

7. References and Sources of Additional Information

- Federal Energy Regulatory Commission (FERC), 1995. New Don Pedro Proceeding P-2299-024 Settlement Agreement. Dated 1995.
- SFPUC 1996. Hetch Hetchy Water & Power Tuolumne River Water Supply Forecasting Model, Volume 1 – Manual and Volume 2 – Operation Manual. Prepared by Hannaford Consulting, Inc., October 10, 1996.
- SFPUC 1997. Memorandum of Understanding Between the City and County of San Francisco Public Utilities Commission and the California Department of Fish and Game Regarding Water Release and Recapture Facilities for Purposes of Improving Native Fisheries on Alameda Creek and Calaveras Creeks. August, 1997.
- SFPUC 2005. Regional Water System Operations Plan. CDM, April 2005.
- SFPUC 2006. Regional Water System Hetch Hetchy Water & Power Operations Plan. URS, August 2006.
- State Water Resources Control Board. Water Quality Control Plan for the San Francisco Bay/Sacramento San Joaquin Delta Estuary, 95-1WR, May 1995.
- Steiner, Daniel B., Consulting Engineer. Unimpaired Flow Estimates for HH/LSM System – East Bay Locales. Draft, August 2006.